

# PERIODIC MAINTENANCE AND TUNE-UP PROCEDURES

## CONTENTS

<b>PERIODIC MAINTENANCE SCHEDULE</b> .....	<b>2- 1</b>
<b>PERIODIC MAINTENANCE CHART</b> .....	<b>2- 1</b>
<b>LUBRICATION POINTS</b> .....	<b>2- 2</b>
<b>MAINTENANCE AND TUNE-UP PROCEDURES</b> .....	<b>2- 3</b>
<b>EXHAUST PIPE BOLTS</b> .....	<b>2- 3</b>
<b>AIR CLEANER</b> .....	<b>2- 3</b>
<b>TAPPET CLEARANCE</b> .....	<b>2- 4</b>
<b>SPARK PLUG</b> .....	<b>2- 8</b>
<b>ENGINE OIL AND OIL FILTER</b> .....	<b>2- 9</b>
<b>FUEL LINE</b> .....	<b>2-10</b>
<b>FUEL FILTER</b> .....	<b>2-10</b>
<b>CARBURETOR</b> .....	<b>2-10</b>
<b>CLUTCH</b> .....	<b>2-11</b>
<b>DRIVE CHAIN</b> .....	<b>2-11</b>
<b>COOLING SYSTEM</b> .....	<b>2-13</b>
<b>BRAKE</b> .....	<b>2-14</b>
<b>TIRE</b> .....	<b>2-16</b>
<b>STEERING</b> .....	<b>2-17</b>
<b>FRONT FORK</b> .....	<b>2-18</b>
<b>REAR SUSPENSION</b> .....	<b>2-18</b>
<b>CHASSIS BOLTS AND NUTS</b> .....	<b>2-19</b>
<b>COMPRESSION PRESSURE CHECK</b> .....	<b>2-21</b>
<b>OIL PRESSURE CHECK</b> .....	<b>2-22</b>

## 2-1 PERIODIC MAINTENANCE AND TUNE-UP PROCEDURES

### PERIODIC MAINTENANCE SCHEDULE

**IMPORTANT:** The periodic maintenance intervals and service requirements have been established in accordance with EPA regulations. Following these instructions will ensure that the motorcycle will not exceed emission standards and it will also ensure the reliability and performance of the motorcycle.

The chart below lists the recommended intervals for all the required periodic service work necessary to keep the motorcycle operating at peak performance and economy. Mileages are expressed in terms of kilometer, miles and time for your convenience.

**NOTE:**

*More frequent servicing may be performed on motorcycles that are used under severe conditions however, it is not necessary for ensuring emission level compliance.*

### PERIODIC MAINTENANCE CHART

Item	Interval	km	1000	6000	12000	18000	24000	
		miles	600	4000	7500	11000	15000	
		months	2	12	24	36	48	
Exhaust pipe bolts		—	T	T	T	T	T	
Air cleaner		—	I	I	R	I	I	
Tappet clearance		—	—	I	—	I	I	
Spark plug		—	I	R	I	R	R	
Engine oil		R	R	R	R	R	R	
Engine oil filter		R	—	R	—	R	R	
Fuel line (EVAP hose . . . . . California model only)		—	I	I	I	I	I	
		Replace every 4 years						
Fuel filter		—	—	C	—	C	C	
Engine idle rpm (Carburetor)		I	I	I	I	I	I	
Throttle cable play (Carburetor)		I	I	I	I	I	I	
Clutch cable play		—	I	I	I	I	I	
Drive chain		I	I	I	I	I	I	
		Lubricate every 1000 km (600 miles)						
Radiator hose		—	I	I	I	I	I	
		Replace every 4 years						
Engine coolant		Replace every 2 years						
Brake		I	I	I	I	I	I	
Brake hose		—	I	I	I	I	I	
		Replace every 4 years						
Brake fluid		—	I	I	I	I	I	
		Replace every 2 years						
Tire		—	I	I	I	I	I	
Steering		I	—	I	—	I	I	
Front fork		—	—	I	—	I	I	
Rear suspension		—	—	I	—	I	I	
Chassis bolts and nuts		T	T	T	T	T	T	

*I = Inspection and adjust, clean, lubricate or replace as necessary*

*C = Clean*



*R = Replace*

*T = Tighten*

## LUBRICATION POINTS

Proper lubrication is important for smooth operation and long life of each working part of the motorcycle.

Major lubrication points are indicated below.

-  Oil
-  Grease

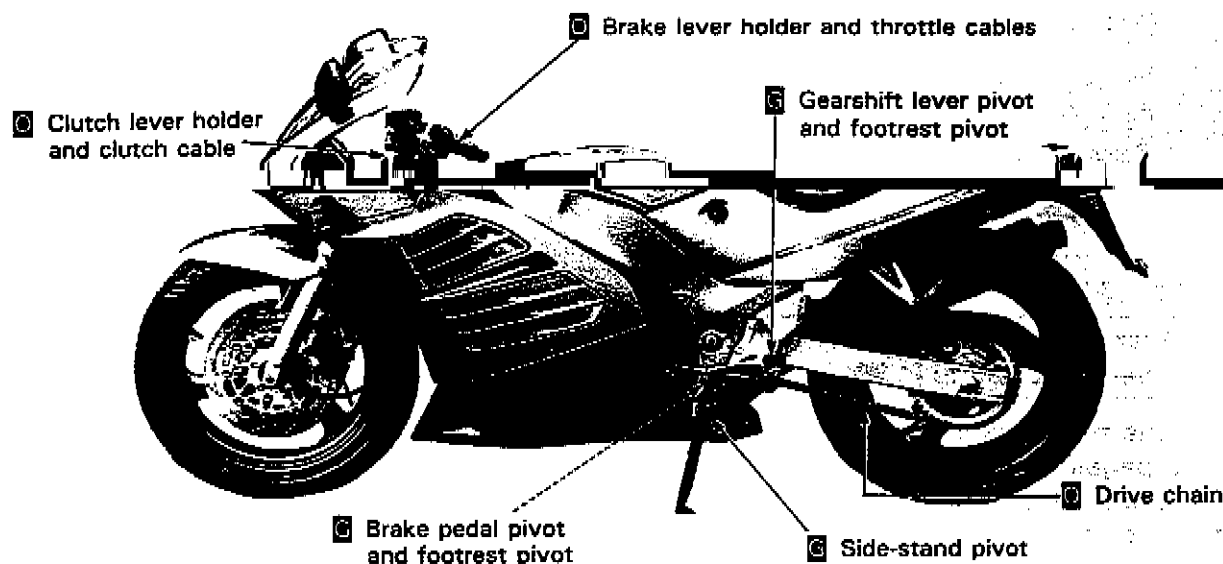

### NOTE:

- \* Before lubricating each part, clean off any rusty spots and wipe off any grease, oil, dirt or grime.
- \* Lubricate exposed parts which are subject to rust, with a rust preventative spray whenever the motorcycle has been operated under wet or rainy conditions.

## 2.3 PERIODIC MAINTENANCE AND TUNE-UP PROCEDURES

### MAINTENANCE AND TUNE-UP PROCEDURES

This section describes the servicing procedures for each item of the Periodic Maintenance requirements.

#### EXHAUST PIPE BOLTS

**Tighten Every 6000 km (4000 miles, 12 months).**

- Remove the lower cowling assembly. (Refer to page 7-2.)
- Remove the radiator mounting bolts. (Refer to page 3-4.)
- Tighten the exhaust pipe clamp bolts and muffler mounting bolts to the specified torque with a torque wrench.

Exhaust pipe clamp bolt 18–28 N·m

& Muffler mounting bolt : (1.8–2.8 kg·m, 13.0–20.0 lb·ft)

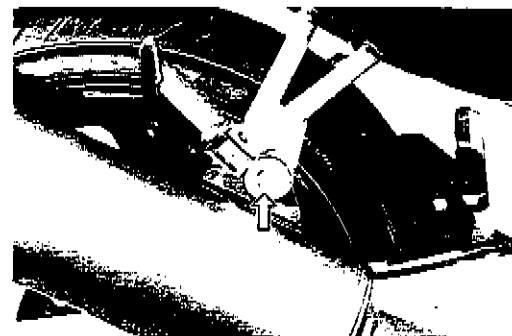
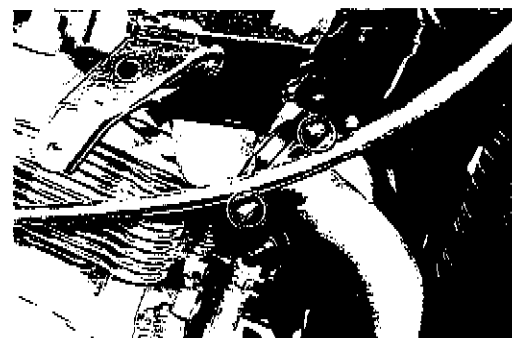
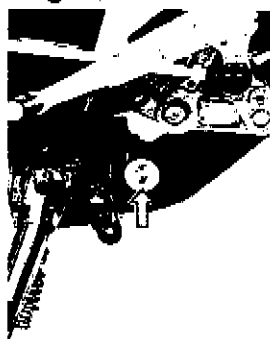
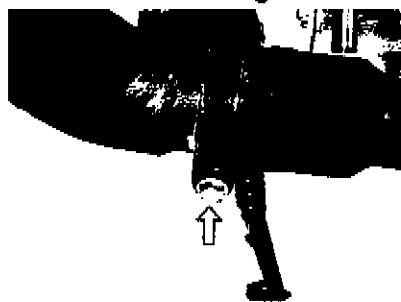

#### AIR CLEANER

**Inspect Every 6000 km (4000 miles, 12 months) and Replace Every 18000 km (11000 miles, 36 months).**

- Remove the seats, frame cover assembly and fuel tank. (Refer to pages 7-5 and 4-5.)
- Remove the air cleaner element by removing the screws.
- Carefully use air hose to blow the dust from the cleaner element.

#### CAUTION:

Always use air pressure on the inside of the air cleaner element. If air pressure is used on the outside, dirt will be forced into the pores of the air cleaner element thus restricting air flow through the air cleaner element.

- Reinstall the cleaned or new air cleaner element in the reverse order of removal.
- When installing the air cleaner element in the cleaner case, make sure that the  mark (A) comes upward.

#### CAUTION:

If driving under dusty condition, clean the air cleaner element more frequently. The surest way to accelerate engine wear is to use the engine without the element or to use a ruptured element. Make sure that the air cleaner is in good condition at all times. Life of the engine depends largely on this component!

#### NOTE:

When you clean the air cleaner element, drain water from the air cleaner drain hose by removing the drain plug.

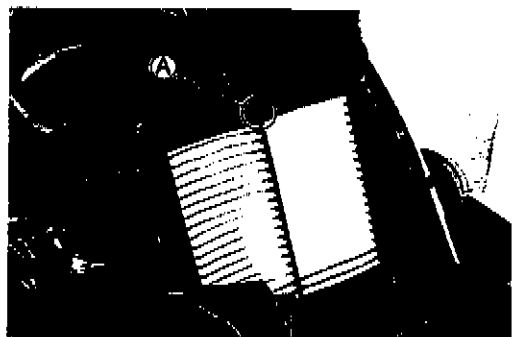
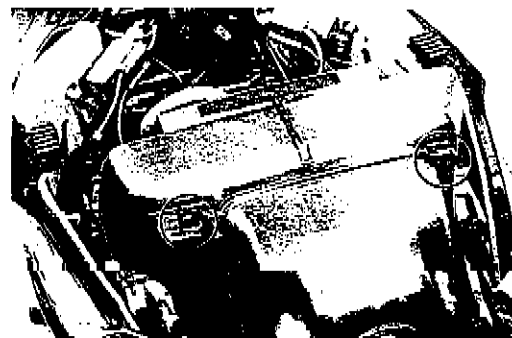

## TAPPET CLEARANCE

**Inspect Every 12000 km (7500 miles, 24 months).**

- Remove the seats, frame cover assembly, lower cowling assembly and fuel tank. (Refer to pages 7-2, 7-5 and 4-5.)
- Remove the air cleaner box and carburetors. (Refer to pages 3-2 and 3.)
- Remove all the spark plugs.
- Remove the cylinder head cover. (Refer to page 3-10.)

The tappet clearance specification is different for both intake and exhaust valves.

Tappet clearance adjustment must be checked and adjusted, 1) at the time of periodic inspection, 2) when the valve mechanism is serviced, and 3) when the camshafts are disturbed by removing them for servicing.

**Tappet clearance (when cold):**

**IN. : 0.10—0.20 mm (0.004—0.008 in)**

**EX.: 0.20—0.30 mm (0.008—0.012 in)**

### NOTE:

- \* The cam must be at positions, **A** or **B**, in order to check the tappet clearance, or to adjust tappet clearance. Clearance readings should not be taken with the cam in any other position than these two positions.
- \* The clearance specification is for **COLD** state.
- \* To turn the crankshaft for clearance checking, be sure to use a 19-mm wrench, and rotate in the normal running direction. All spark plugs should be removed.

- Turn crankshaft to bring the "T" mark on the rotor to the center of pick-up coil and also to bring the notches ① in the right ends of both camshafts (Ex and In) to the positions shown. In this condition, read the tappet clearance at the valves **C** (In and Ex of No.1 cylinder, Ex of No.2 and In of No.3).
- Use a thickness gauge between the tappet and the cam. If the clearance is out of specification, bring it into the specified range.

**09900-20803: Thickness gauge**

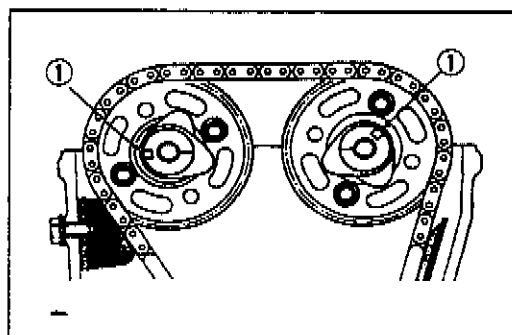
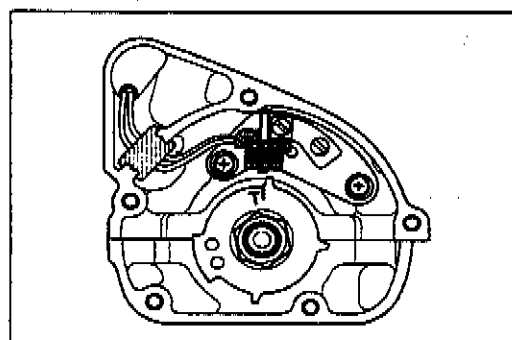
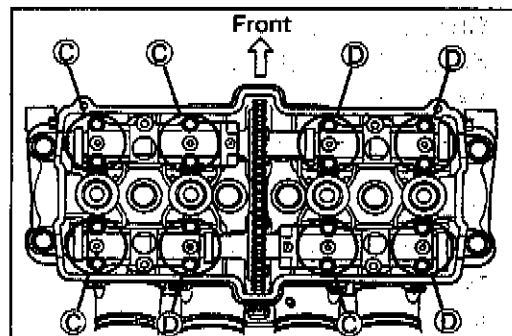
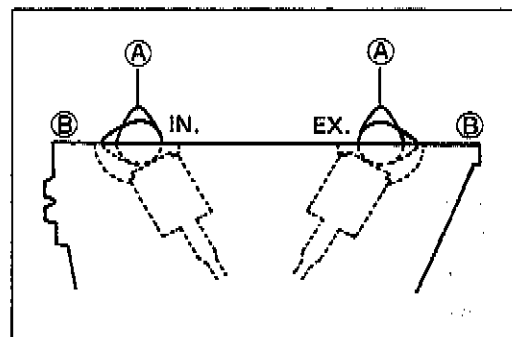

## 2.5 PERIODIC MAINTENANCE AND TUNE-UP PROCEDURES

- Turn the crankshaft 360° (one rotation) to bring the "T" mark on the rotor to the center of pick-up coil and also to bring the notches ① to the positions shown.
- Read the clearance at the remaining valves ② and adjust the clearance if necessary.

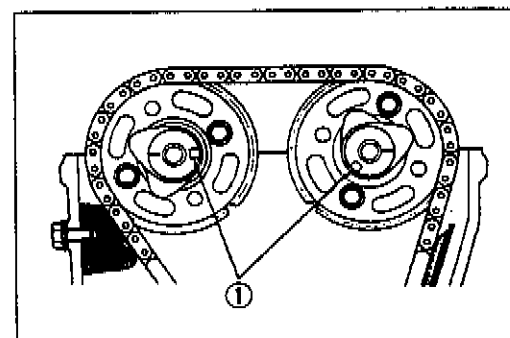

Cam Position	Notch ① position	
	Intake Camshaft	Exhaust Camshaft
Ⓒ		
Ⓓ		

### TAPPET CLEARANCE ADJUSTMENT

The clearance is adjusted by replacing the existing tappet shim by a thicker or thinner shim.

- Remove the intake or exhaust camshafts. (Refer to page 3-11.)
- Remove the tappet and shim by fingers or magnetic hand. (Refer to page 3-21.)
- Check the figures printed on the shim. These figures indicate the thickness of the shim, as illustrated.
- Select a replacement shim that will provide a clearance within the specified range. For the purpose of this adjustment, a total of 21 sizes of tappet shim are available ranging from 1.20 to 2.20 mm in steps of 0.05 mm. Fit the selected shim to the valve stem end, with numbers toward tappet. Be sure to check shim size with micrometer to ensure its size.

Refer to the tappet shim selection table for details.

#### NOTE:

- \* *Be sure to apply engine oil to tappet shim top and bottom faces.*
- \* *When seating the tappet shim, be sure to face figure printed surface to the tappet.*
- After replacing the tappet shim and camshafts, rotate the engine so that the tappet is depressed fully. This will squeeze out oil trapped between the shim and the tappet that could cause an incorrect measurement, then check the clearance again to confirm that it is within the specified range.
- When installing the cylinder head cover, apply SUZUKI BOND NO.1207B to the head cover groove and cam end caps. (Refer to page 3-64.)
- Tighten the head cover bolts to the specified torque. (Refer to page 3-65.)

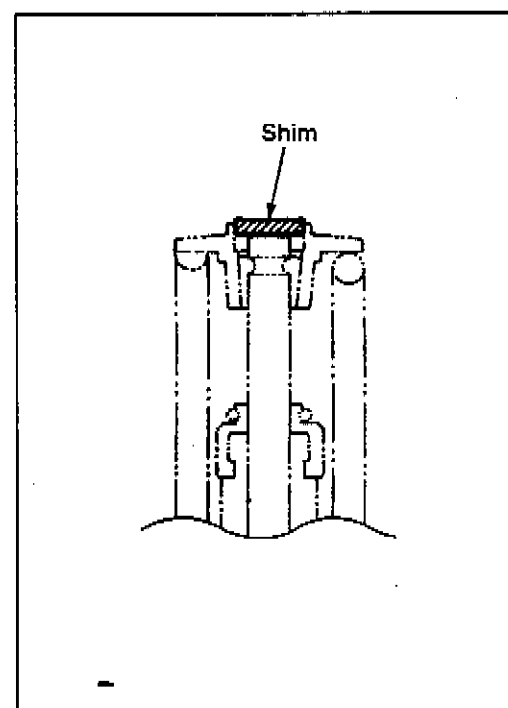
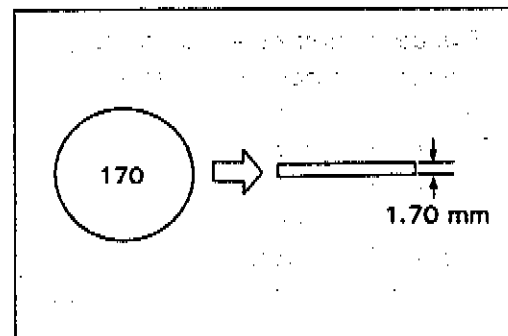

(INTAKE SIDE)

TAPPET SHIM SET NO. (12800-05820)

TAPPET SHIM SELECTION TABLE (INTAKE)  
TAPPET SHIM NO.(12892-05C00-x x x)

MEA-SURED TAPPET CLEARANCE (mm)	SUFFIX NO.	SPECIFIED CLEARANCE/NO ADJUSTMENT REQUIRED																			
		120	125	130	135	140	145	150	155	160	165	170	175	180	185	190	195	200	205	210	215
0.00-0.04	1.20	1.25	1.30	1.35	1.40	1.45	1.50	1.55	1.60	1.65	1.70	1.75	1.80	1.85	1.90	1.95	2.00	2.05	2.10	2.15	2.20
0.05-0.09	1.20	1.25	1.30	1.35	1.40	1.45	1.50	1.55	1.60	1.65	1.70	1.75	1.80	1.85	1.90	1.95	2.00	2.05	2.10	2.15	2.20
0.10-0.20	1.20	1.25	1.30	1.35	1.40	1.45	1.50	1.55	1.60	1.65	1.70	1.75	1.80	1.85	1.90	1.95	2.00	2.05	2.10	2.15	2.20
0.21-0.26	1.30	1.35	1.40	1.45	1.50	1.55	1.60	1.65	1.70	1.75	1.80	1.85	1.90	1.95	2.00	2.05	2.10	2.15	2.20	2.20	2.20
0.28-0.30	1.35	1.40	1.45	1.50	1.55	1.60	1.65	1.70	1.75	1.80	1.85	1.90	1.95	2.00	2.05	2.10	2.15	2.20	2.20	2.20	2.20
0.31-0.35	1.40	1.45	1.50	1.55	1.60	1.65	1.70	1.75	1.80	1.85	1.90	1.95	2.00	2.05	2.10	2.15	2.20	2.20	2.20	2.20	2.20
0.36-0.40	1.45	1.50	1.55	1.60	1.65	1.70	1.75	1.80	1.85	1.90	1.95	2.00	2.05	2.10	2.15	2.20	2.20	2.20	2.20	2.20	2.20
0.41-0.45	1.50	1.55	1.60	1.65	1.70	1.75	1.80	1.85	1.90	1.95	2.00	2.05	2.10	2.15	2.20	2.20	2.20	2.20	2.20	2.20	2.20
0.46-0.50	1.55	1.60	1.65	1.70	1.75	1.80	1.85	1.90	1.95	2.00	2.05	2.10	2.15	2.20	2.20	2.20	2.20	2.20	2.20	2.20	2.20
0.51-0.55	1.60	1.65	1.70	1.75	1.80	1.85	1.90	1.95	2.00	2.05	2.10	2.15	2.20	2.20	2.20	2.20	2.20	2.20	2.20	2.20	2.20
0.56-0.60	1.65	1.70	1.75	1.80	1.85	1.90	1.95	2.00	2.05	2.10	2.15	2.20	2.20	2.20	2.20	2.20	2.20	2.20	2.20	2.20	2.20
0.61-0.65	1.70	1.75	1.80	1.85	1.90	1.95	2.00	2.05	2.10	2.15	2.20	2.20	2.20	2.20	2.20	2.20	2.20	2.20	2.20	2.20	2.20
0.66-0.70	1.75	1.80	1.85	1.90	1.95	2.00	2.05	2.10	2.15	2.20	2.20	2.20	2.20	2.20	2.20	2.20	2.20	2.20	2.20	2.20	2.20
0.71-0.75	1.80	1.85	1.90	1.95	2.00	2.05	2.10	2.15	2.20	2.20	2.20	2.20	2.20	2.20	2.20	2.20	2.20	2.20	2.20	2.20	2.20
0.76-0.80	1.85	1.90	1.95	2.00	2.05	2.10	2.15	2.20	2.20	2.20	2.20	2.20	2.20	2.20	2.20	2.20	2.20	2.20	2.20	2.20	2.20
0.81-0.85	1.90	1.95	2.00	2.05	2.10	2.15	2.20	2.20	2.20	2.20	2.20	2.20	2.20	2.20	2.20	2.20	2.20	2.20	2.20	2.20	2.20
0.86-0.90	1.95	2.00	2.05	2.10	2.15	2.20	2.20	2.20	2.20	2.20	2.20	2.20	2.20	2.20	2.20	2.20	2.20	2.20	2.20	2.20	2.20
0.91-0.95	2.00	2.05	2.10	2.15	2.20	2.20	2.20	2.20	2.20	2.20	2.20	2.20	2.20	2.20	2.20	2.20	2.20	2.20	2.20	2.20	2.20
0.96-1.00	2.05	2.10	2.15	2.20	2.20	2.20	2.20	2.20	2.20	2.20	2.20	2.20	2.20	2.20	2.20	2.20	2.20	2.20	2.20	2.20	2.20
1.01-1.05	2.10	2.15	2.20	2.20	2.20	2.20	2.20	2.20	2.20	2.20	2.20	2.20	2.20	2.20	2.20	2.20	2.20	2.20	2.20	2.20	2.20
1.06-1.10	2.15	2.20	2.20	2.20	2.20	2.20	2.20	2.20	2.20	2.20	2.20	2.20	2.20	2.20	2.20	2.20	2.20	2.20	2.20	2.20	2.20
1.11-1.15	2.20	2.20	2.20	2.20	2.20	2.20	2.20	2.20	2.20	2.20	2.20	2.20	2.20	2.20	2.20	2.20	2.20	2.20	2.20	2.20	2.20

HOW TO USE THIS CHART:

- I. Measure tappet clearance. "ENGINE IS COLD"
- II. Measure present shim size.
- III. Match clearance in vertical column with present shim size in horizontal column.

EXAMPLE

Tappet clearance is 0.23 mm  
Present shim size 1.70 mm  
Shim size to be used 1.80 mm



## SPARK PLUG

Inspect at 6000 km (4000 miles, 12 months), 18000 km (11000 miles, 36 months) and Replace Every 12000 km (7500 miles, 24 months).

- Remove the seats, frame cover assembly and fuel tank. (Refer to pages 7-5 and 4-5.)
- Remove all the spark plugs.

### NOTE:

If it is difficult to remove the spark plug cap, pry up it with a screwdriver.

09930-10121: Spark plug socket wrench set

09930-14530: Universal joint

09914-24510: T handle

09900-20803: Thickness gauge

	Standard	Cold type	Hot type
NGK	CR9E	CR10E	CR8E
ND	U27ESR-N	U31ESR-N	U24ESR-N

### CARBON DEPOSIT

Check to see the carbon deposit on the plug.

If the carbon is deposited, remove it with a spark plug cleaner machine or carefully using a tool with a pointed end.

### SPARK PLUG GAP

Measure the plug gap with a thickness gauge if it is correct. If not, adjust it to the following gap.

Spark plug gap	Standard
	0.7—0.8 mm (0.028—0.032 in)

09900-20803: Thickness gauge

### ELECTRODE'S CONDITION

Check to see the worn or burnt condition of the electrodes. If it is extremely worn or burnt, replace the plug. And also replace the plug if it has a broken insulator, damaged thread, etc.

### CAUTION:

Confirm the thread size and reach when replacing the plug. If the reach is too short, carbon will be deposited on the screw portion of the plug hole and engine damage may result.

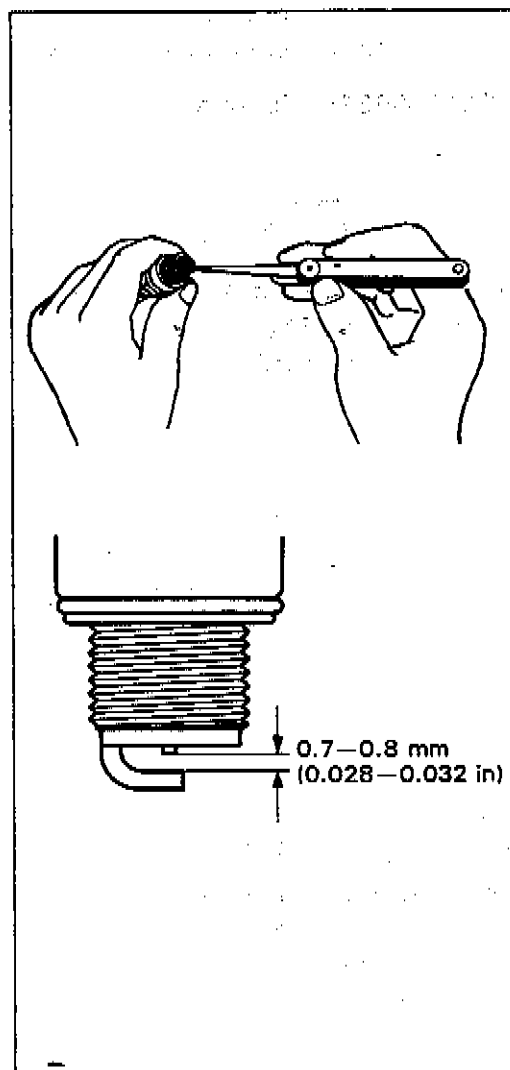

**2-9 PERIODIC MAINTENANCE AND TUNE-UP PROCEDURES****ENGINE OIL AND OIL FILTER****(ENGINE OIL)**

Replace Initially at 1000 km (600 miles, 2 months) and Every 6000 km (4000 miles, 12 months) thereafter.

**OIL FILTER**

Replace Initially at 1000 km (600 miles, 2 months) and Every 12000 km (7500 miles, 24 months) thereafter.

Oil should be changed while the engine is warm. Oil filter replacement at the above intervals, should be done together with the engine oil change.

- Keep the motorcycle upright.
- Place an oil pan below the engine, and drain the oil by removing the drain plug ① and filler cap ②.
- Remove the oil filter ③ by using the oil filter wrench. (Special tool ④)
- Apply engine oil lightly to the gasket of the new filter before installation.
- Install the new filter turning it by hand until you feel that the filter gasket contacts the mounting surface. Then tighten it 2 turns using the oil filter wrench. (Special tool ④)

**09915-40610: Oil filter wrench****NOTE:**

To properly tighten the filter, use the special tool. Never tighten the filter by hand.

- Fit the drain plug ① securely, and pour fresh oil through the oil filler. The engine will hold about 3.3 L (3.5 US qt) of oil. Use an API classification of SE or SF oil with SAE 10W/40 viscosity.
- Start up the engine and allow it to run for several seconds at idling speed.
- Turn off the engine and wait about one minute, then check the oil level through the inspection window ④. If the level is below mark "F", add oil to that level.

**NECESSARY AMOUNT OF ENGINE OIL**

Oil change: 3.0 L (3.2/2.6 US/Imp qt)

Filter change: 3.3 L (3.5/2.9 US/Imp qt)

Overhaul engine: 3.9 L (4.1/3.4 US/Imp qt)

**CAUTION:**

Use SUZUKI MOTORCYCLE GENUINE OIL FILTER only, since the other make's genuine filters and after-market parts may differ in thread specifications (thread diameter and pitch), filtering performance and durability, which could cause engine damage or oil leaks. Suzuki automobile genuine oil filter is also not usable for the motorcycles.

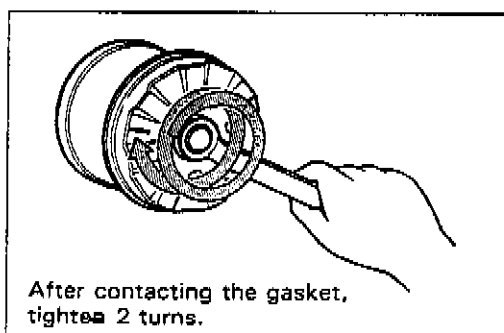
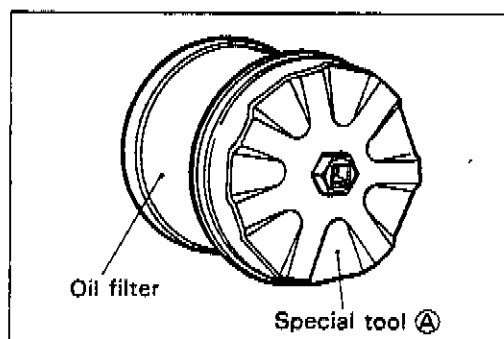
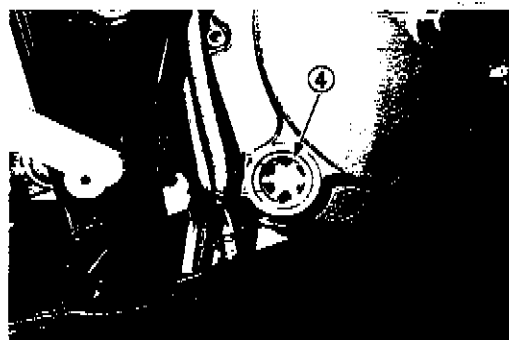
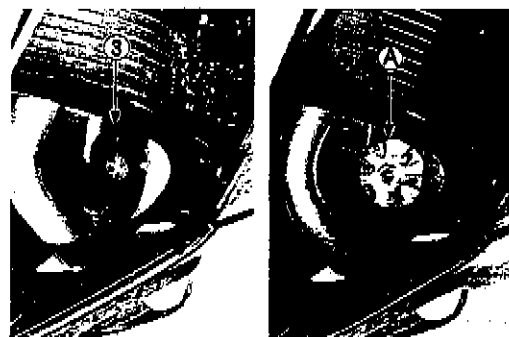
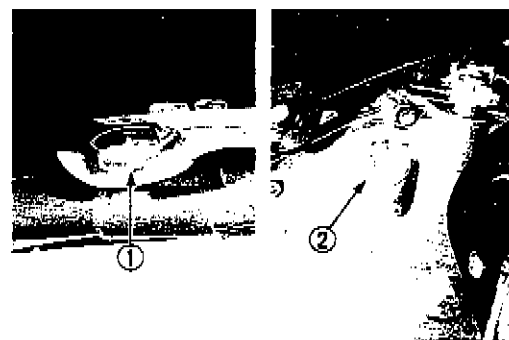

## FUEL LINE (EVAP HOSE ... California model only)

Inspect Every 6000 km (4000 miles, 12 months).  
Replace Every 4 years.

## FUEL FILTER

Clean Every 12000 km (7500 miles, 24 months).

(Refer to page 4-5.)

## CARBURETOR

### IDLE RPM (Idling adjustment)

Inspect Initially at 1000 km (600 miles, 2 months) and  
Every 6000 km (4000 miles, 12 months) thereafter.

#### NOTE:

Make this adjustment when the engine is hot.

- Connect a tachometer.
- Start up the engine and set its speed at anywhere between 1200 and 1400 r/min by turning throttle stop screw ①.

#### Engine idle speed:

1300 ± 100 r/min ..... E-03

1350 ± 100 r/min ..... E-33

## THROTTLE CABLE PLAY

### Pulling cable play ①

There should be 0.5—1.0 mm (0.02—0.04 in) play ① in the throttle cable. Adjust the throttle cable play with the following procedures.

- Loosen the lock nut ① and turn the adjuster ② in or out until the specified play is obtained.
- Tighten the lock nut ① while holding the adjuster.

### Returning cable play ②

- Adjust the returning cable to the specified play in the same manner as the pulling cable play adjustment.

Throttle cable play (① and ②): 0.5—1.0 mm (0.02—0.04 in)

#### WARNING:

After the adjustment is completed, check that handlebar movement does not raise the engine idle speed and that the throttle grip returns smoothly and automatically.

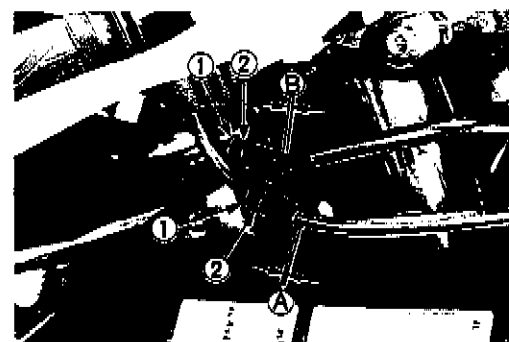

**2-11 PERIODIC MAINTENANCE AND TUNE-UP PROCEDURES****CLUTCH**

**Inspect Every 6000 km (4000 miles, 12 months).**

- Remove the lower cowling assembly.
- Loosen the cable adjuster lock nut ① and screw in the cable adjuster ② .
- Loosen the cable adjuster lock nut ③ and screw in the cable adjuster ④ to provide a play in the cable.
- Adjust the clutch lever play A with the cable adjuster ④ until play of the clutch lever is within the following value.

Clutch lever play A

10–15 mm (0.4–0.6 in)

- If the specified play can not be obtained with the cable adjuster ④ , carry out the adjustment with the cable adjuster ② on the clutch lever side.
- After adjusting the play, tighten the both cable adjuster lock nuts, ① and ③.

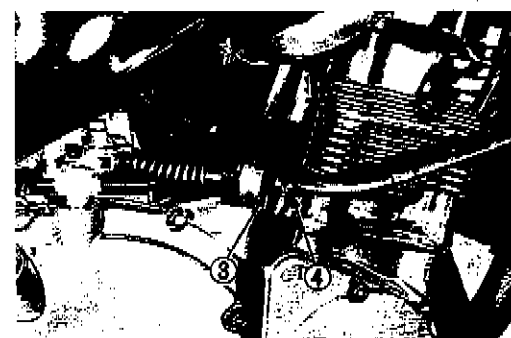
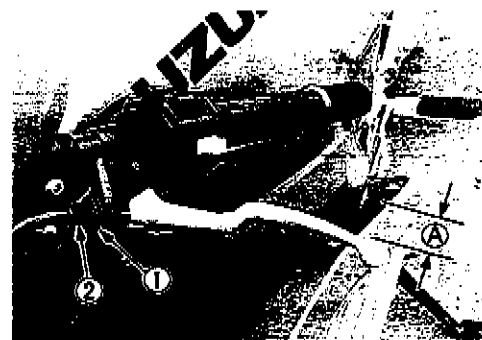
**DRIVE CHAIN**

**Inspect Initially at 1000 km (600 miles, 2 months) and Every 6000 km (4000 miles, 12 months) thereafter. Lubricate Every 1000 km (600 miles).**

Visually check the drive chain for the possible defects listed below. (Support the motorcycle by a jack and a wooden block, turn the rear wheel slowly by hand with the transmission shifted to Neutral.)

- |                           |                             |
|---------------------------|-----------------------------|
| * Loose pins              | * Excessive wear            |
| * Damaged rollers         | * Improper chain adjustment |
| * Dry or rusted links     | * Missing O-ring seals      |
| * Kinked or binding links |                             |

If any defects are found, the drive chain must be replaced.

**NOTE:**

*When replacing the drive chain, replace the drive chain and sprockets as a set.*

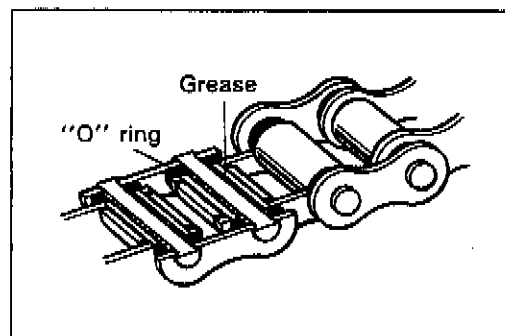

**CHECKING**

- Remove the axle cotter pin. (For E-03, 28 and 33 models)
  - Loosen the axle nut ① .
  - Tense the drive chain fully by turning both chain adjusters ② .
- 
- Count out 21 pins (20 pitches) on the chain and measure the distance between the two points. If the distance exceeds the service limit, the chain must be replaced.

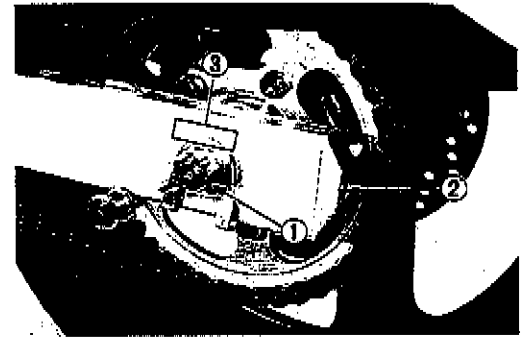

Drive chain 20-pitch length	Service Limit
	319.4 mm (12.6 in)

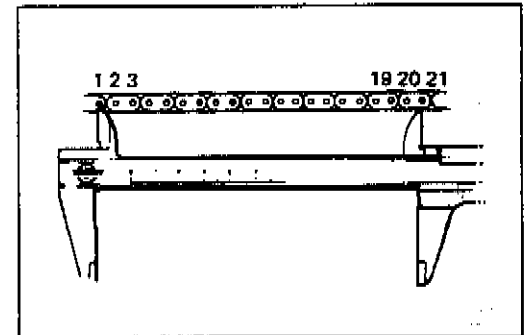
**ADJUSTING**

- Loosen or tighten both chain adjusters ② until the chain has 30–40 mm (1.2–1.6 in) of slack in the middle between engine and rear sprockets. The mark ③ on both chain adjusters must be at the same position on the scale to ensure that the front and rear wheels are correctly aligned.
- Place the motorcycle on its side-stand for accurate adjustment.
- After adjusting the drive chain, tighten the axle nut ① securely.
- Tighten both chain adjusters ② securely.

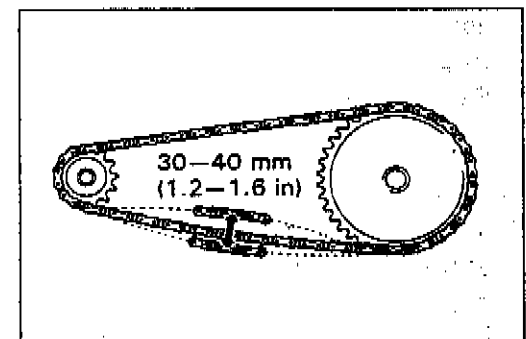

Rear axle nut: 85–115 N·m  
(8.5–11.5 kg·m, 61.5–83.0 lb-ft)

**CLEANING AND LUBRICATING**

- Wash the chain with kerosene. If the chain tends to rust quickly, the intervals must be shortened.

**CAUTION:**

Do not use trichlene, gasoline or any similar fluids: These fluids have too great a dissolving power for this chain and, what is more important, they can damage the "O"-rings (or seals) confining the grease in the bush to pin clearance. Remember, high durability comes from the presence of grease in that clearance.

- After washing and drying the chain, oil it with a heavy-weight motor oil.

**CAUTION:**

- \* Do not use any oil sold commercially as "drive chain oil". Such oil can damage the "O"-rings (or seals).
- \* The standard drive chain TAKASAGO RK50GSVZ1 or DAIDO DID50VA7. SUZUKI recommends that this standard drive chain should be used for the replacement.

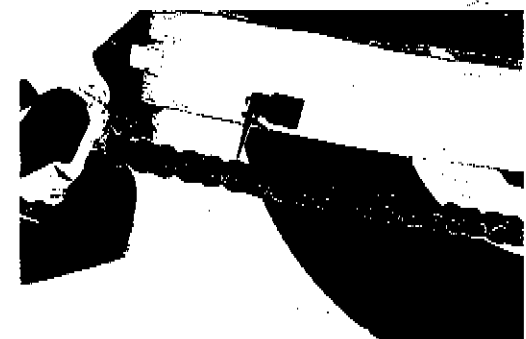

## 2-13 PERIODIC MAINTENANCE AND TUNE-UP PROCEDURES

### COOLING SYSTEM

Inspect Every 6000 km (4000 miles, 12 months).  
 Replace engine coolant Every 2 years.  
 Replace radiator hoses Every 4 years.

#### ENGINE COOLANT LEVEL

- Keep the motorcycle upright.
- Check the engine coolant level by observing the upper and lower limit lines on the engine coolant reservoir.
- If the level is below the lower limit line, add engine coolant to the upper limit line from the engine coolant reservoir filler.

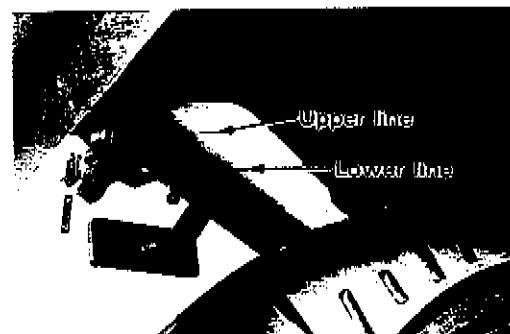

#### ENGINE COOLANT CHANGE

- Remove the seats, frame cover assembly, lower cowling assembly and right side of cowling upper panel. (Refer to pages 7-2 and 5.)
- Remove the radiator cap ① and disconnect the water hose ②, and drain engine coolant.



#### WARNING:

- \* Do not open the radiator cap when the engine is hot, as you may be injured by escaping hot liquid or vapor.
- \* Engine coolant may be harmful if swallowed or if it comes in contact with skin or eyes. If engine coolant gets into the eyes or in contact with the skin, flush thoroughly with plenty of water. If swallowed, induce vomiting and call physician immediately!

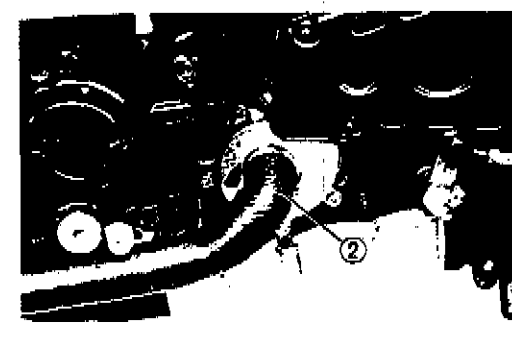

- Flush the radiator with fresh water if necessary.
- Connect the water hose ② securely.
- Pour the specified engine coolant up to the radiator inlet.

#### NOTE:

For engine coolant information, refer to page 5-4.

- Close the radiator cap ① securely.
- After warming up and cooling down the engine, add the specified engine coolant up to the engine coolant reservoir.



#### CAUTION:

Repeat above procedure several times and make sure that the radiator is filled with engine coolant up to the engine coolant reservoir.

Engine coolant capacity: 2450 ml (2.6/2.2 US/Imp qt)

## BRAKE

### (BRAKE)

Inspect Initially at 1000 km (600 miles, 2 months) and Every 6000 km (4000 miles, 12 months) thereafter.

### (BRAKE HOSE AND BRAKE FLUID)

Inspect Every 6000 km (4000 miles, 12 months). Replace hoses Every 4 years. Replace fluid Every 2 years.

### BRAKE FLUID LEVEL

- Keep the motorcycle upright and place the handlebars straight.
- Check the brake fluid level by observing the lower limit lines on the front and rear brake fluid reservoirs.
- When the level is below the lower limit line, replenish with brake fluid that meets the following specification.

**Specification and Classification: DOT4**

### WARNING:

The brake system of this motorcycle is filled with a glycol-based brake fluid. Do not use or mix different types of fluid such as silicone-based or petroleum-based. Do not use any brake fluid taken from old, used or unsealed containers. Never re-use brake fluid left over from the last servicing or stored for a long period.

### WARNING:

Brake fluid, if it leaks, will interfere with safe running and immediately discolor painted surfaces. Check the brake hoses and hose joints for cracks and oil leakage before riding.

### BRAKE PADS

The extent of brake pad wear can be checked by observing the grooved limit line ① on the pad. When the wear exceeds the grooved limit line, replace the pads with new ones. (Refer to pages 7-17 and 7-35.)

### CAUTION:

Replace the brake pad as a set, otherwise braking performance will be adversely affected.

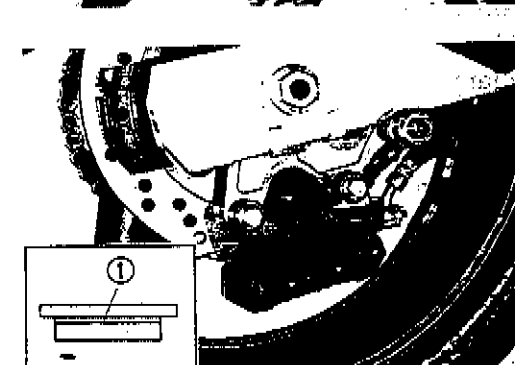
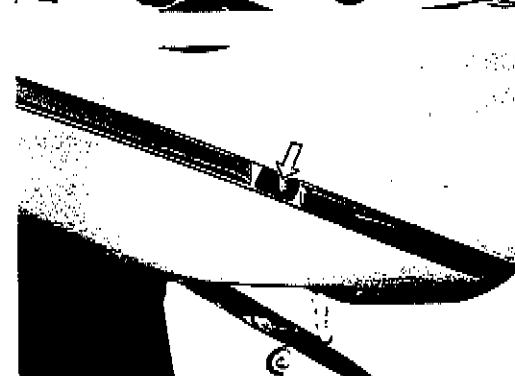
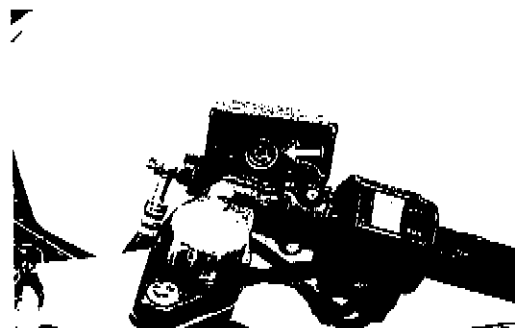

## 2-15 PERIODIC MAINTENANCE AND TUNE-UP PROCEDURES

### BRAKE PEDAL HEIGHT

- Loosen the lock nut ① and rotate the push rod ② to locate brake pedal 50–60 mm (2.0–2.4 in) ③ below the top face of the footrest.
- Retighten the lock nut ① to secure the push rod ② in the proper position.

Brake pedal height ③ : 50–60 mm (2.0–2.4 in)

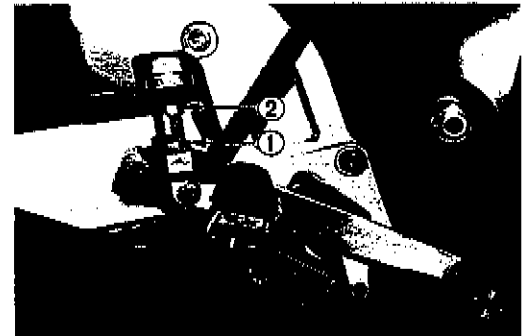
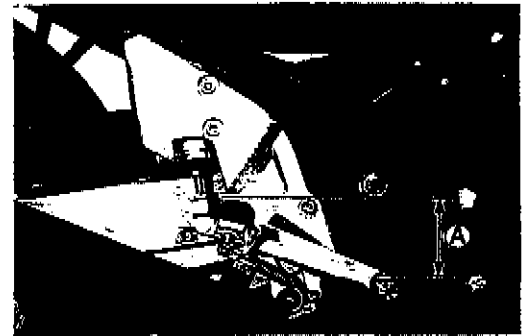

### BRAKE LIGHT SWITCH

Adjust the rear brake light switch so that the brake light will come on just before pressure is felt when the brake pedal is depressed.



### AIR BLEEDING THE BRAKE FLUID CIRCUIT

Air trapped in the fluid circuit acts like a cushion to absorb a large proportion of the pressure developed by the master cylinder and thus interferes with the full braking performance of the brake caliper. The presence of air is indicated by "sponginess" of the brake lever and also by lack of braking force. Considering the danger to which such trapped air exposes the machine and rider, it is essential that, after re-mounting the brake and restoring the brake system to the normal condition, the brake fluid circuit be purged of air in the following manner:

- Fill up the master cylinder reservoir to the "UPPER" line. Replace the reservoir cap to prevent entry of dirt.
- Attach a pipe to the caliper bleeder valve, and insert the free end of the pipe into a receptacle.

**Bleeder valve**

**tightening torque: 6–9 N·m**

**(0.6–0.9 kg-m, 4.5–6.5 lb-ft)**

- **Front brake:** Bleed the air from the air bleeder valve.
- Squeeze and release the brake lever several times in rapid succession and squeeze the lever fully without releasing it. Loosen the bleeder valve by turning it a quarter of a turn so that the brake fluid runs into the receptacle; this will remove the tension of the brake lever causing it to touch the handlebar grip. Then, close the valve, pump and squeeze the lever, and open the valve. Repeat this process until the fluid flowing into the receptacle no longer contains air bubbles.

**NOTE:**

*Replenish the brake fluid in the reservoir as necessary while bleeding the brake system. Make sure that there is always some fluid visible in the reservoir.*

- Close the bleeder valve, and disconnect the pipe. Fill the reservoir to the "UPPER" line.

**CAUTION:**

**Handle brake fluid with care: the fluid reacts chemically with paint, plastics, rubber materials etc.**

- The only difference between bleeding the front and rear brakes is that the rear master cylinder is actuated by a pedal.

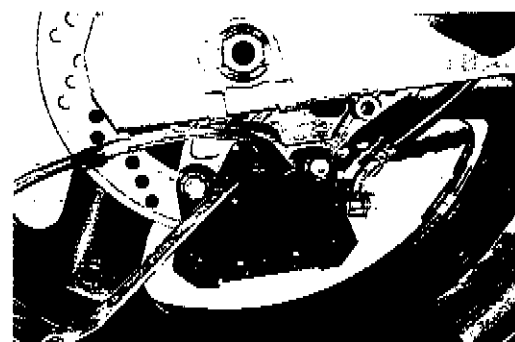
**TIRE**

**Inspect Every 6000 km (4000 miles, 12 months).**

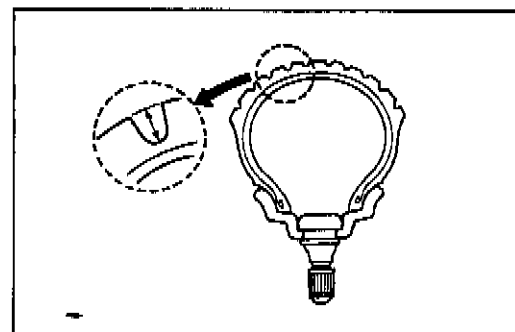

## 2-17 PERIODIC MAINTENANCE AND TUNE-UP PROCEDURES

### TIRE TREAD CONDITION

Operating the motorcycle with excessively worn tires will decrease riding stability and consequently invite a dangerous situation. It is highly recommended to replace a tire when the remaining depth of tire tread reaches the following specification.

**Tire tread depth limit: FRONT 1.6 mm (0.06 in)**  
**REAR 2.0 mm (0.08 in)**

tain the correct tire pressure for good roadability or shorter tire life will result. Cold inflation tire pressure is as follows.

COLD INFLATION TIRE PRESSURE	SOLO RIDING			DUAL RIDING		
	kPa	kg/cm <sup>2</sup>	psi	kPa	kg/cm <sup>2</sup>	psi
FRONT	225	2.25	33	250	2.50	36
REAR	250	2.50	36	290	2.90	42

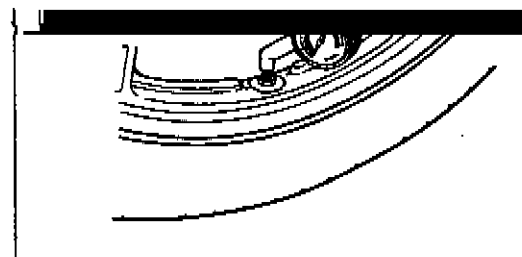

### CAUTION:

The standard tire fitted on this motorcycle is 120/70 ZR17 for front (DUNLOP D202F) and 160/60 ZR17 for rear (DUNLOP D202). The use of tires other than those specified may cause instability. It is highly recommended to use a SUZUKI Genuine Tire.

### STEERING

Inspect Initially at 1000 km (600 miles, 2 months) and Every 12000 km (7500 miles, 24 months) thereafter.

Taper roller type bearings are used on the steering system for better handling. Steering should be adjusted properly for smooth turning of handlebars and safe running. Overtight steering prevents smooth turning of the handlebars and too loose steering will cause poor stability. Check that there is no play in the front fork assembly by supporting the machine so that the front wheel is off the ground, with the wheel straight ahead, grasp the lower fork tubes near the axle and pull forward. If play is found, perform steering bearing adjustment as described in page 7-33 of this manual.



## **FRONT FORK**

**Inspect Every 12000 km (7500 miles, 24 months).**

Inspect the front forks for oil leakage, scoring or scratches on the outer surface of the inner tubes. Replace any defective parts, if necessary. (Refer to page 7-24.)

## **REAR SUSPENSION**

**Inspect Every 12000 km (7500 miles, 24 months).**

Inspect the rear shock absorber for oil leakage and check that there is no play in the swingarm assembly.

**2-19 PERIODIC MAINTENANCE AND TUNE-UP PROCEDURES****CHASSIS BOLTS AND NUTS**

**Tighten Initially at 1000 km (600 miles, 2 months) and Every 6000 km (4000 miles, 12 months) thereafter.**

The nuts and bolts listed below are important safety related parts. They must be retightened when necessary to the specified torque with a torque wrench. (Refer to page 2-20 for the locations of the following nuts and bolts on the motorcycle.)

Item	N-m	kg-m	lb-ft
① Steering stem head nut	80-100	8.0-10.0	58.0-72.5
② Front fork upper clamp bolt	18-28	1.8-2.8	13.0-20.0
③ Front fork lower clamp bolt	18-28	1.8-2.8	13.0-20.0
④ Front fork cap bolt	30-40	3.0-4.0	21.5-29.0
⑤ Front axle	50-80	5.0-8.0	36.0-58.0
⑥ Front axle pinch bolt	18-28	1.8-2.8	13.0-20.0
⑦ Handlebar holder mounting bolt and nut	22-35	2.2-3.5	16.0-25.5
⑧ Handlebar set bolt	18-28	1.8-2.8	13.0-20.0
⑨ Front brake master cylinder mounting bolt	8-12	0.8-1.2	6.0-8.5
⑩ Front brake caliper mounting bolt	20-30	2.0-3.0	14.5-21.5
⑪ Brake hose union bolt (Cylinder & Caliper)	15-20	1.5-2.0	11.0-14.5
⑫ Air bleeder valve (Front & Rear)	6-9	0.6-0.9	4.5-6.5
⑬ Front and rear disc bolt	18-28	1.8-2.8	13.0-20.0
⑭ Front footrest bracket mounting bolt	18-28	1.8-2.8	13.0-20.0
⑮ Swingarm pivot nut	85-115	8.5-11.5	61.5-83.0
⑯ Front footrest nut	42-66	4.2-6.6	30.5-47.5
⑰ Rear shock absorber mounting nut (Upper & Lower)	40-60	4.0-6.0	29.0-43.5
⑱ Rear cushion lever/rod mounting nut	70-100	7.0-10.0	50.5-72.5
⑲ Rear brake caliper mounting bolt	20-30	2.0-3.0	14.5-21.5
⑳ Rear brake caliper housing bolt	30-36	3.0-3.6	21.5-26.0
㉑ Rear brake master cylinder mounting bolt	18-28	1.8-2.8	13.0-20.0
㉒ Rear axle nut	85-115	8.5-11.5	61.5-83.0
㉓ Rear sprocket nut	48-72	4.8-7.2	35.0-52.0

PERIODIC MAINTENANCE AND TUNE-UP PROCEDURES 2-20

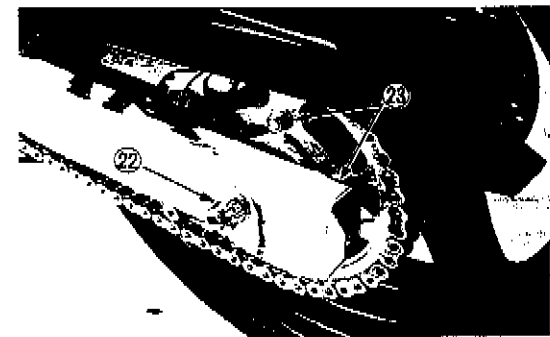
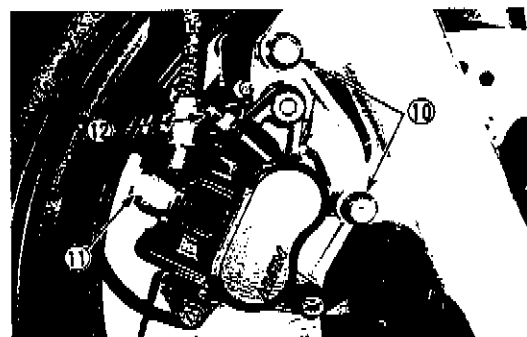
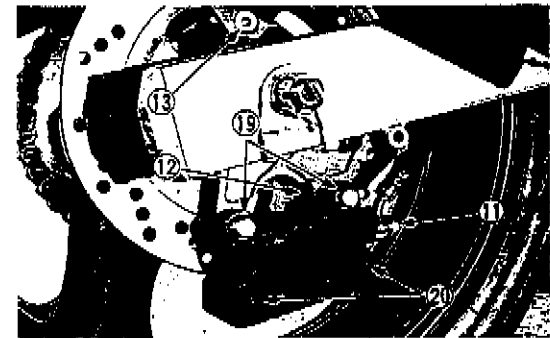
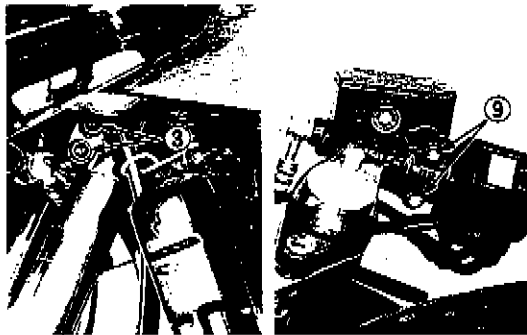
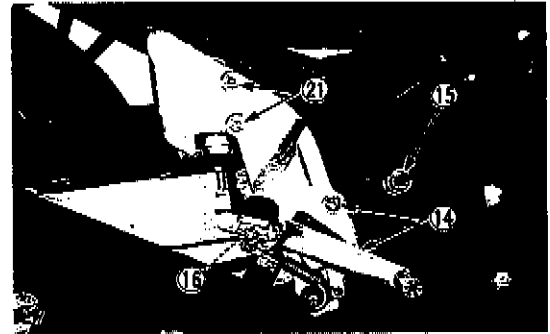
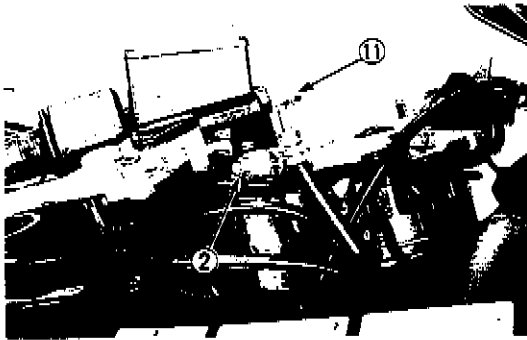
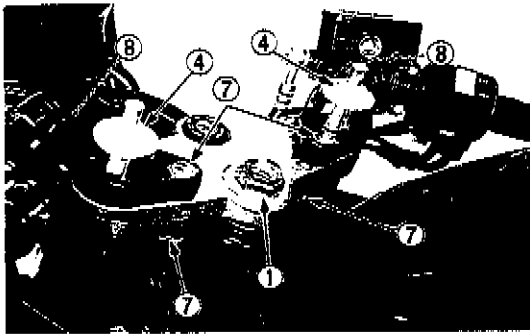

## 2-21 PERIODIC MAINTENANCE AND TUNE-UP PROCEDURES

### COMPRESSION PRESSURE CHECK

The compression of a cylinder is a good indicator of its internal condition.

The decision to overhaul the cylinder is often based on the results of a compression test. Periodic maintenance records kept at your dealership should include compression readings for each maintenance service.

#### COMPRESSION PRESSURE SPECIFICATION

Standard	Limit	Difference
1000—1500 kPa (10—15 kg/cm <sup>2</sup> ) (142—213 psi)	800 kPa (8 kg/cm <sup>2</sup> ) (114 psi)	200 kPa (2 kg/cm <sup>2</sup> ) (28 psi)

**Low compression pressure can indicate any of the following conditions:**

- \* Excessively worn cylinder wall
- \* Worn-down piston or piston rings
- \* Piston rings stuck in grooves
- \* Poor seating of valves
- \* Ruptured or otherwise defective cylinder head gasket

**Overhaul the engine in the following cases:**

- \* Compression pressure in one of the cylinders is less than 800 kPa (8 kg/cm<sup>2</sup>, 114 psi).
- \* Difference in compression pressure between any two cylinders is more than 200 kPa (2 kg/cm<sup>2</sup>, 28 psi).
- \* All compression pressure are below 1000 kPa (10 kg/cm<sup>2</sup>, 142 psi) even when they measure more than 800 kPa (8 kg/cm<sup>2</sup>, 114 psi).

### COMPRESSION TEST PROCEDURE

#### NOTE:

- \* *Before testing the engine for compression pressure, make sure that the cylinder head bolts are tightened to the specified torque values and valves are properly adjusted.*
- \* *Have the engine warmed up by idling before testing.*
- \* *Be sure that the battery used is in fully-charged condition.*

Remove the parts concerned and test the compression pressure in the following manner.

- Remove the seats, fuel tank and lower cowling. (Refer to pages 7-2 and 4-5.)
- Remove all the spark plugs.
- Fit the compression gauge in one of the plug holes, while taking care that the connection tight.
- Keep the throttle grip in full-open position.
- While cranking the engine a few seconds with the starter, and record the maximum gauge reading as the compression of that cylinder.
- Repeat this procedure with the other cylinders.

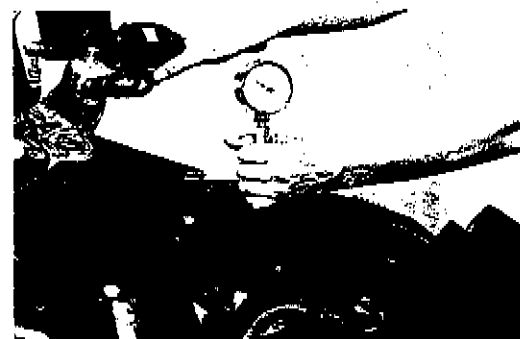

**09915-64510: Compression gauge**

**09915-63310: Adaptor**

## OIL PRESSURE CHECK

Check periodically the oil pressure in the engine to judge roughly the condition of the moving parts.

### OIL PRESSURE SPECIFICATION

Above 300 kPa (3.0 kg/cm <sup>2</sup> , 43 psi) Below 600 kPa (6.0 kg/cm <sup>2</sup> , 85 psi)	at 3000 r/min., Oil temp. at 60°C (140°F)
--	---

If the oil pressure is lower or higher than the specification, the following causes may be considered.

#### LOW OIL PRESSURE

- \* Clogged oil filter
- \* Oil leakage from the oil passage way
- \* Damaged O-ring
- \* Defective oil pump
- \* Combination of above items

#### HIGH OIL PRESSURE

- \* Used a engine oil which is too heavy a weight
- \* Clogged oil passage way
- \* Combination of above items

### OIL PRESSURE TEST PROCEDURE

Start the engine and check if the oil pressure indicator light is turned on. If it keeps on lighting, check the oil pressure indicator light circuit. If it is in good condition, check the oil pressure in the following manner.

- Remove the lower cowling.
- Remove the main oil gallery plug.
- Install the oil pressure gauge ① with adaptor in the position shown in the figure.
- Warm up the engine as follows:  
Summer 10 min. at 2000 r/min.  
Winter 20 min. at 2000 r/min.
- After warming up, increase the engine speed to 3000 r/min. (with the engine tachometer), and read the oil pressure gauge.

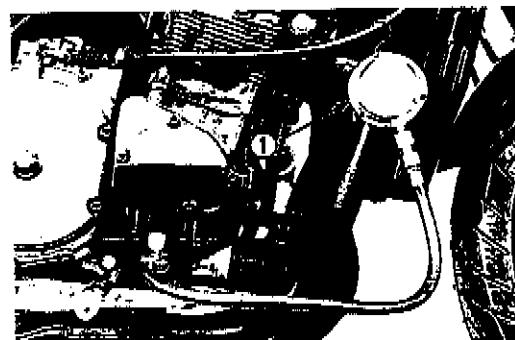

09915-74510: Oil pressure gauge

09915-74540: Adaptor

09915-77330: Meter (for high pressure)

