

SERVICING INFORMATION

CONTENTS

TROUBLESHOOTING	8- 1
WIRING DIAGRAM	8- 9
WIRE HARNESS, CABLE AND HOSE ROUTING	8-12
COWLING AND FRAME COVER SET UP	8-23
SPECIAL TOOLS	8-26
TIGHTENING TORQUE	8-29
SERVICE DATA	8-32

B-1 SERVICING INFORMATION

TROUBLESHOOTING

ENGINE

Complaint	Symptom and possible causes	Remedy
<p>Engine will not start, or is hard to start.</p>	<p>Compression too low</p> <ol style="list-style-type: none"> 1. Out of adjustment valve clearance. 2. Worn valve guides or poor seating of valves. 3. Mistiming valves. 4. Excessively worn piston rings. 5. Worn-down cylinder bores. 6. Too slowly starter motor cranks. 7. Poor seating of spark plugs. <p>Plugs not sparking</p> <ol style="list-style-type: none"> 1. Fouled spark plugs. 2. Wet spark plugs. 3. Defective ignition coil. 4. Open or short in high-tension cords. 5. Defective signal generator or ignitor unit. <p>No fuel reaching the carburetors</p> <ol style="list-style-type: none"> 1. Clogged fuel tank vent hose. 2. Clogged or defective fuel/cook. 3. Defective fuel pump or ignitor unit. 4. Defective carburetor needle valve. 5. Clogged fuel hose or fuel filter. 	<p>Adjust. Repair or replace. Adjust. Replace. Replace or rebore. See electrical section. Retighten.</p> <p>Clean. Clean and dry. Replace. Replace. Replace.</p> <p>Clean or replace. Clean or replace. Replace. Replace. Clean or replace.</p>
<p>Engine stalls easily.</p>	<ol style="list-style-type: none"> 1. Fouled spark plugs. 2. Defective signal generator or ignitor unit. 3. Clogged fuel hose. 4. Clogged jets in carburetors. 5. Out of adjustment valve clearance. 	<p>Clean. Replace. Clean. Clean. Adjust.</p>
<p>Noisy engine.</p>	<p>Excessive valve chatter</p> <ol style="list-style-type: none"> 1. Too large valve clearance. 2. Weakened or broken valve springs. 3. Worn tappet or cam surface. 4. Worn and burnt camshaft journal. <p>Noise seems to come from piston</p> <ol style="list-style-type: none"> 1. Worn down pistons or cylinders. 2. Fouled with carbon combustion chambers. 3. Worn piston pins or piston pin bore. 4. Worn piston rings or ring grooves. <p>Noise seems to come from timing chain</p> <ol style="list-style-type: none"> 1. Stretched chain. 2. Worn sprockets. 3. Not working tension adjuster. <p>Noise seems to come from clutch</p> <ol style="list-style-type: none"> 1. Worn splines of countershaft or hub. 2. Worn teeth of clutch plates. 3. Distorted clutch plates, driven and drive. 4. Worn clutch release bearing. 5. Weakened clutch dampers. 	<p>Adjust. Replace. Replace. Replace.</p> <p>Replace. Clean. Replace. Replace.</p> <p>Replace. Replace. Repair or replace.</p> <p>Replace. Replace. Replace. Replace. Replace the primary driven gear.</p>

Complaint	Symptom and possible causes	Remedy
Noisy engine.	<p>Noise seems to come from crankshaft</p> <ol style="list-style-type: none"> 1. Due to wear rattling bearings. 2. Worn and burnt big-end bearings. 3. Worn and burnt journal bearings. 4. Too large thrust clearance. <p>Noise seems to come from transmission</p> <ol style="list-style-type: none"> 1. Worn or rubbing gears. 2. Badly worn splines. 3. Worn or rubbing primary gears. 4. Badly worn bearings. <p>Noise seems to come from water pump</p> <ol style="list-style-type: none"> 1. Too much play on pump shaft bearing. 2. Worn or damaged mechanical seal. 3. Touches pump case and impeller. 	<p>Replace. Replace. Replace. Replace thrust bearing.</p> <p>Replace. Replace. Replace. Replace.</p> <p>Replace. Replace. Replace.</p>
Slipping clutch.	<ol style="list-style-type: none"> 1. Out of adjustment or loss of play clutch control. 2. Weakened clutch springs. 3. Worn or distorted pressure plate. 4. Distorted clutch plates, driven and drive. 	<p>Adjust. Replace. Replace. Replace.</p>
Dragging clutch.	<ol style="list-style-type: none"> 1. Out of adjustment or too much play clutch control. 2. Some clutch springs weakened. 3. Distorted pressure plate or clutch plate. 	<p>Adjust. Replace. Replace.</p>
Transmission will not shift.	<ol style="list-style-type: none"> 1. Broken gearshift cam. 2. Distorted gearshift forks. 3. Worn gearshift pawl. 	<p>Replace. Replace. Replace.</p>
Transmission will not shift back.	<ol style="list-style-type: none"> 1. Broken return spring on shift shaft. 2. Rubbing or sticky shift shaft. 3. Distorted or worn gearshift forks. 	<p>Replace. Repair or replace. Replace.</p>
Transmission jumps out of gear.	<ol style="list-style-type: none"> 1. Worn shifting gears on driveshaft or countershaft. 2. Distorted or worn gearshift forks. 3. Weakened stopper spring on gearshift stopper. 4. Worn gearshift pawl. 	<p>Replace. Replace. Replace. Replace.</p>
Engine idles poorly.	<ol style="list-style-type: none"> 1. Out of adjustment valve clearance. 2. Poor seating of valves. 3. Defective valve guides. 4. Worn tappet or cam surface. 5. Too wide spark plug gaps. 6. Defective ignition coil. 7. Defective signal generator or ignitor unit. 8. Out of adjustment in carburetors float-chamber fuel level. 9. Clogged jets or imbalance of carburetors. 10. Defective fuel pump or ignitor unit. 	<p>Adjust. Replace or repair. Replace. Replace. Adjust or replace. Replace. Replace. Adjust.</p> <p>Clean or adjust. Replace.</p>

8.3 SERVICING INFORMATION

Complaint	Symptom and possible causes	Remedy
Engine runs poorly in high speed range.	<ol style="list-style-type: none"> 1. Weakened valve springs. 2. Worn camshafts. 3. Valve timing out of adjustment. 4. Too narrow spark plug gaps. 5. Ignition not advanced sufficiently due to poorly working timing advance circuit. 6. Defective ignition coil. 7. Defective signal generator or ignitor unit. 8. Too low float-chamber fuel level. 9. Clogged air cleaner element. 10. Clogged fuel hose, resulting in inadequate fuel supply to carburetors. 11. Defective fuel pump or ignitor unit. 	<p>Replace. Replace. Adjust. Adjust. Replace ignitor unit.</p> <p>Replace. Replace. Adjust. Clean. Clean and prime.</p> <p>Replace.</p>
Dirty or heavy exhaust smoke.	<ol style="list-style-type: none"> 1. Too much engine oil in the engine. 2. Worn piston rings or cylinders. 3. Worn valve guides. 4. Scored or scuffed cylinder walls. 5. Worn valves stems. 6. Defective stem seal. 7. Worn oil ring side rails. 	<p>Check with inspection window drain out excess oil.</p> <p>Replace. Replace. Rebore or replace. Replace. Replace. Replace.</p>
Engine lacks power.	<ol style="list-style-type: none"> 1. Loss of valve clearance. 2. Weakened valve springs. 3. Out of adjustment valve timing. 4. Worn piston rings or cylinders. 5. Poor seating of valves. 6. Fouled spark plug. 7. Incorrect spark plug. 8. Clogged jets in carburetors. 9. Out of adjustment float-chamber fuel level. 10. Clogged air cleaner element. 11. Loose carburetor balancing screw. 12. Sucking air from intake pipe. 13. Too much engine oil. 14. Defective fuel pump or ignitor unit. 	<p>Adjust. Replace. Adjust. Replace. Repair. Clean or replace. Adjust or replace. Clean. Adjust. Clean. Retighten. Retighten or replace. Drain out excess oil. Replace.</p>
Engine overheats.	<ol style="list-style-type: none"> 1. Heavy carbon deposit on piston crowns. 2. Not enough oil in the engine. 3. Defective oil pump or clogged oil circuit. 4. Too low in float chambers fuel level. 5. Sucking air from intake pipes. 6. Use incorrect engine oil. 7. Defective cooling system. 	<p>Clean. Add oil. Replace or clean. Adjust. Retighten or replace. Change. See radiator section.</p>

SERVICING INFORMATION 8-4**RADIATOR**

Complaint	Symptom and possible causes	Remedy
Engine overheats.	<ol style="list-style-type: none"> 1. Not enough cooling water. 2. Clogged with dirt or trashes radiator core. 3. Erratic thermostat, stuck in closed position. 4. Faulty cooling fan. 5. Defective thermo-switch. 6. Clogged water passage. 7. Air trapped in the cooling circuit. 8. Defective water pump. 9. Use incorrect coolant. 	Add coolant. Clean. Replace. Repair or replace. Replace. Clean. Bleed out air. Replace. Replace.
Engine overcools.	<ol style="list-style-type: none"> 1. Erratic thermostat, stuck in full-open position. 2. Defective thermo-switch. 3. Extremely cold weather. 	Replace. Replace. Put on the radiator cover.

CARBURETOR

Complaint	Symptom and possible causes	Remedy
Trouble with starting.	<ol style="list-style-type: none"> 1. Clogged starter jet. 2. Clogged starter pipe. 3. Air leaking from a joint between starter body and carburetor. 4. Air leaking from carburetor's joint or vacuum gauge joint. 5. Not operation properly starter plunger. 	Clean. Clean. Check starter body and carburetor for tightness, adjust and replace gasket. Check and adjust. Check and adjust.
Idling or low-speed trouble.	<ol style="list-style-type: none"> 1. Clogged or loose pilot jet, pilot air jet. 2. Air leaking from carburetor's joint, vacuum gauge joint, or starter. 3. Clogged pilot outlet or bypass. 4. Not fully closed starter plunger. 	Check and clean. Check and adjust. Check and clean. Check and adjust.
Medium-or high speed trouble.	<ol style="list-style-type: none"> 1. Clogged main jet or main air jet. 2. Clogged needle jet. 3. Not operating properly throttle valve. 4. Clogged fuel filter. 	Check and clean. Check and clean. Check throttle valve for operation. Check and clean.
Overflow and fuel level fluctuations.	<ol style="list-style-type: none"> 1. Worn or damaged needle valve. 2. Broken spring in needle valve. 3. Not working properly float. 4. Foreign matter has adhered to needle valve. 5. Too high or low fuel level. 6. Defective fuel pump or ignitor unit. 	Replace. Replace. Check and adjust. Clean. Adjust float height. Replace.

8-5 SERVICING INFORMATION**ELECTRICAL**

Complaint	Symptom and possible causes	Remedy
No sparking or poor sparking.	<ol style="list-style-type: none"> 1. Defective ignition coil. 2. Defective spark plugs. 3. Defective signal generator or ignitor unit. 	<p>Replace. Replace. Replace.</p>
Spark plug soon become fouled with carbon.	<ol style="list-style-type: none"> 1. Mixture too rich. 2. Idling speed set too high. 3. Incorrect gasoline. 4. Dirty element in air cleaner. 5. Too cold spark plugs. 	<p>Adjust carburetors. Adjust carburetors. Change. Clean. Replace with hot type plugs.</p>
Spark plugs become fouled too soon.	<ol style="list-style-type: none"> 1. Worn piston rings. 2. Worn piston or cylinders. 3. Excessive clearance of valve stems in valve guides. 4. Worn stem oil seal. 	<p>Replace. Replace. Replace. Replace.</p>
Spark plug electrodes overheat or burn.	<ol style="list-style-type: none"> 1. Too hot spark plugs. 2. Overheated the engine. 3. Loose spark plugs. 4. Too lean mixture. 	<p>Replace with cold type plugs. Tune up. Retighten. Adjust carburetors.</p>
Generator does not charge.	<ol style="list-style-type: none"> 1. Open or short lead wires, or loose lead connections. 2. Shorted, grounded or open generator coils. 3. Shorted or punctured regulator/rectifiers. 	<p>Repair or replace or retighten. Replace. Replace.</p>
Generator does charge, but charging rate is below the specification.	<ol style="list-style-type: none"> 1. Lead wires tend to get shorted or open-circuited or loosely connected at terminals. 2. Grounded or open-circuited stator coils or generator. 3. Defective regulator/rectifier. 4. Defective cell plates in the battery. 	<p>Repair or retighten. Replace. Replace. Replace the battery.</p>
Generator overcharges.	<ol style="list-style-type: none"> 1. Internal short-circuit in the battery. 2. Damaged or defective resistor element in the regulator/rectifier. 3. Poorly grounded regulator/rectifier. 	<p>Replace the battery. Replace. Clean and tighten ground connection.</p>
Unstable charging.	<ol style="list-style-type: none"> 1. Lead wire insulation frayed due to vibration, resulting in intermittent shorting. 2. Internally shorted generator. 3. Defective regulator/rectifier. 	<p>Repair or replace. Replace. Replace.</p>
Starter button is not effective.	<ol style="list-style-type: none"> 1. Run down battery. 2. Defective switch contacts. 3. Not seating properly brushes on commutator in starter motor. 4. Defective starter relay/starter interlock switch. 	<p>Repair or replace. Replace. Repair or replace. Replace.</p>

BATTERY

Complaint	Symptom and possible causes	Remedy
"Sulfation", acidic white powdery substance or spots on surfaces of cell plates.	<ol style="list-style-type: none"> 1. Cracked battery case. 2. Battery has been left in a run-down condition for a long time. 	<p>Replace the battery. Replace the battery.</p>
Battery runs down quickly.	<ol style="list-style-type: none"> 1. Not correct the charging system. 2. Cell plates have lost much of their active material as a result of overcharging. 3. A short-circuit condition exists within the battery. 4. Too low battery voltage. 5. Too old battery. 	<p>Check the generator, regulator/rectifier and circuit connections and make necessary adjustments to obtain specified charging operation. Replace the battery, and correct the charging system. Replace the battery. Recharge the battery fully. Replace the battery.</p>
Battery "sulfation".	<ol style="list-style-type: none"> 1. Too low or too high charging rate. (When not in use batteries should be checked at least once a month to avoid sulfation.) 2. Left unused the battery for too long in cold climate. 	<p>Replace the battery. Replace the battery, if badly sulfated.</p>
Battery discharges too rapidly.	Dirty container top and sides.	Clean.

8-7 SERVICING INFORMATION**CHASSIS**

Complaint	Symptom and possible causes	Remedy
Heavy steering.	<ol style="list-style-type: none"> 1. Overtightened steering stem nut. 2. Broken bearing in steering stem. 3. Distorted steering stem. 4. Not enough pressure in tires. 	Adjust. Replace. Replace. Adjust.
Wobbly handlebars.	<ol style="list-style-type: none"> 1. Loss of balance between right and left front forks. 2. Distorted front fork. 3. Distorted front axle or crooked tire. 	Replace. Repair or replace. Replace.
Wobby front wheel.	<ol style="list-style-type: none"> 1. Distorted wheel rim. 2. Worn front wheel bearings. 3. Defective or incorrect tire. 4. Loose axle. 5. Incorrect front fork oil. 	Replace. Replace. Replace. Retighten. Adjust.
Front suspension too soft.	<ol style="list-style-type: none"> 1. Weakened springs. 2. Not enough fork oil. 	Replace. Replenish.
Front suspension too stiff.	<ol style="list-style-type: none"> 1. Too viscous fork oil. 2. Too much fork oil. 	Replace. Drain excess oil.
Noisy front suspension.	<ol style="list-style-type: none"> 1. Not enough fork oil. 2. Loose bolts on suspension. 	Replenish. Retighten.
Wobbly rear wheel.	<ol style="list-style-type: none"> 1. Distorted wheel rim. 2. Worn rear wheel bearing or swingarm bearings. 3. Defective or incorrect tire. 4. Worn swingarm and rear cushion related bearings. 5. Loose nuts or bolts on rear suspensions. 	Replace. Replace. Replace. Replace. Retighten.
Rear suspension too soft.	<ol style="list-style-type: none"> 1. Weakened shock absorber spring. 2. Improperly set rear suspension adjuster. 3. Leakage oil of shock absorber. 4. Leakage gas of shock absorber. 	Replace. Adjust. Replace. Replace.
Rear suspension too stiff.	<ol style="list-style-type: none"> 1. Improperly set rear suspension adjuster. 2. Bent shock absorber shaft. 3. Bent swingarm. 4. Worn swingarm and rear cushion related bearings. 	Adjust. Replace. Replace. Replace.
Noisy rear suspension.	<ol style="list-style-type: none"> 1. Loose nuts or bolts on rear suspension. 2. Worn swingarm and rear cushion related bearings. 	Retighten. Replace.

SERVICING INFORMATION 8-8**BRAKES**

Complaint	Symptom and possible causes	Remedy
Insufficient brake power.	<ol style="list-style-type: none"> 1. Leakage of brake fluid from hydraulic system. 2. Worn pads. 3. Oil adhesion of engaging surface of pads. 4. Worn disc. 5. Air in hydraulic system. 	Repair or replace. Replace. Clean disc and pads. Replace. Bleed air.
Brake squeaking.	<ol style="list-style-type: none"> 1. Carbon adhesion on pad surface. 2. Tilted pad. 3. Damaged wheel bearing. 4. Loosen front-wheel axle or rear-wheel axle. 5. Worn pads. 6. Foreign material in brake fluid. 7. Clogged return port of master cylinder. 	Repair surface with sandpaper. Modify pad fitting or replace. Replace. Tighten to specified torque. Replace. Replace brake fluid. Disassemble and clean master cylinder.
Excessive brake lever stroke.	<ol style="list-style-type: none"> 1. Air in hydraulic system. 2. Insufficient brake fluid. 3. Improper quality of brake fluid. 	Bleed air. Replenish fluid to specified level; bleed air. Replace with correct fluid.
Leakage of brake fluid.	<ol style="list-style-type: none"> 1. Insufficient tightening of connection joints. 2. Cracked hose. 3. Worn piston and/or cup. 	Tighten to specified torque. Replace. Replace piston and/or cup.

8-9 SERVICING INFORMATION

WIRING DIAGRAM

For U.S.A.

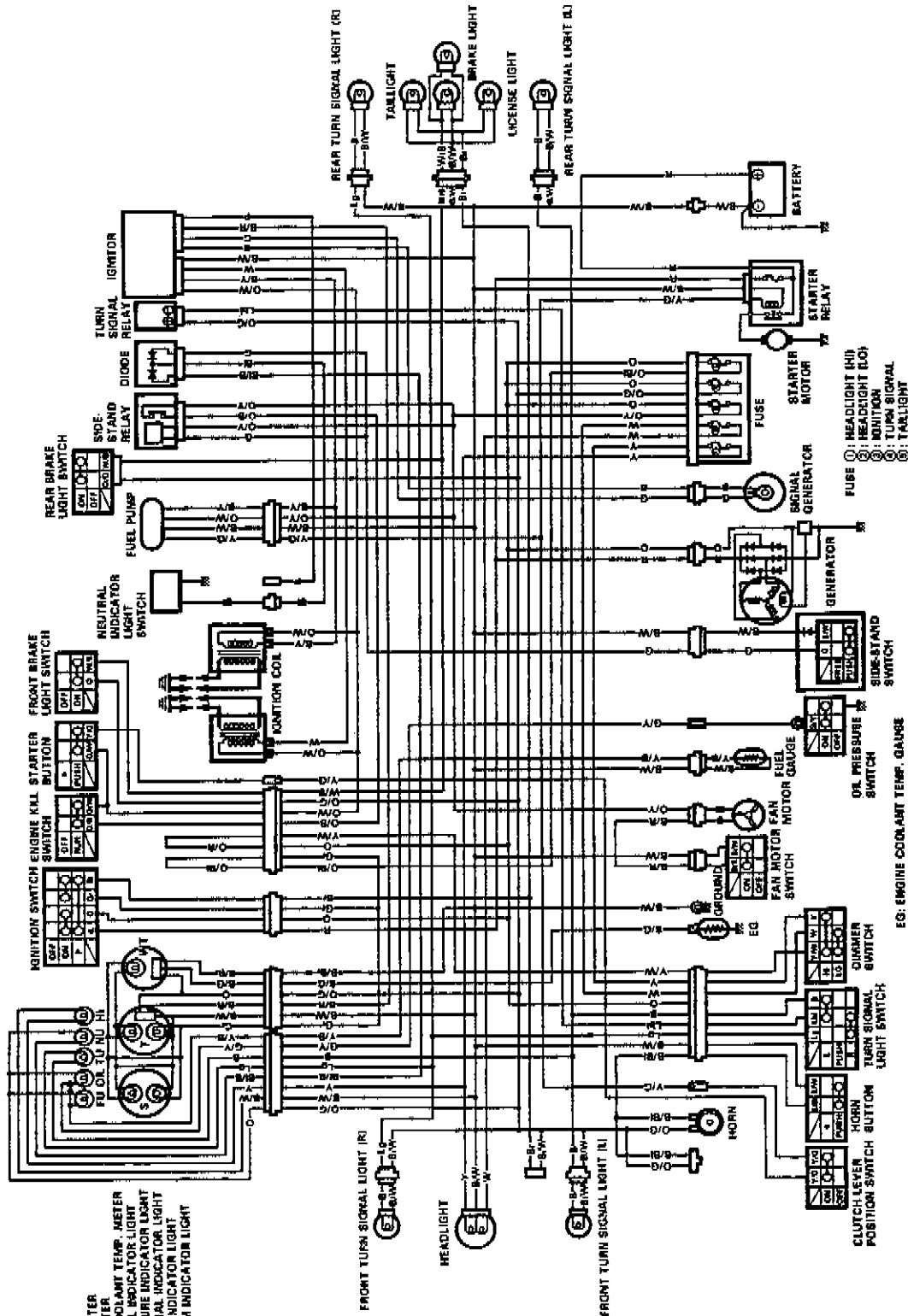

S: SPEEDOMETER
 T: TACHOMETER
 WT: ENGINE COOLANT TEMP. METER
 FU: FUEL LEVEL INDICATOR LIGHT
 CK: OIL PRESSURE INDICATOR LIGHT
 TU: TURN SIGNAL INDICATOR LIGHT
 NS: NEUTRAL INDICATOR LIGHT
 H: HIGH BEAM INDICATOR LIGHT

WIRE COLOR

B	Black	P	Pink	O/W	Orange with White tracer
Bl	Blue	R	Red	O/Y	Orange with Yellow tracer
Br	Brown	W	White	W/B	White with Black tracer
G	Green	Y	Yellow	Y/B	Yellow with Black tracer
Gr	Gray	B/Br	Black with Brown tracer	Y/G	Yellow with Green tracer
Lbl	Light blue	B/G	Black with Green tracer	Y/W	Yellow with White tracer
Lg	Light green	B/Bl	Black with Blue tracer		
O	Orange	B/R	Black with Red tracer		

EG: ENGINE COOLANT TEMP. GAUGE

FUSE ①: HEADLIGHT (H)
 ②: HEADLIGHT (L)
 ③: HORN
 ④: TURN SIGNAL
 ⑤: TAILLIGHT

For Australia

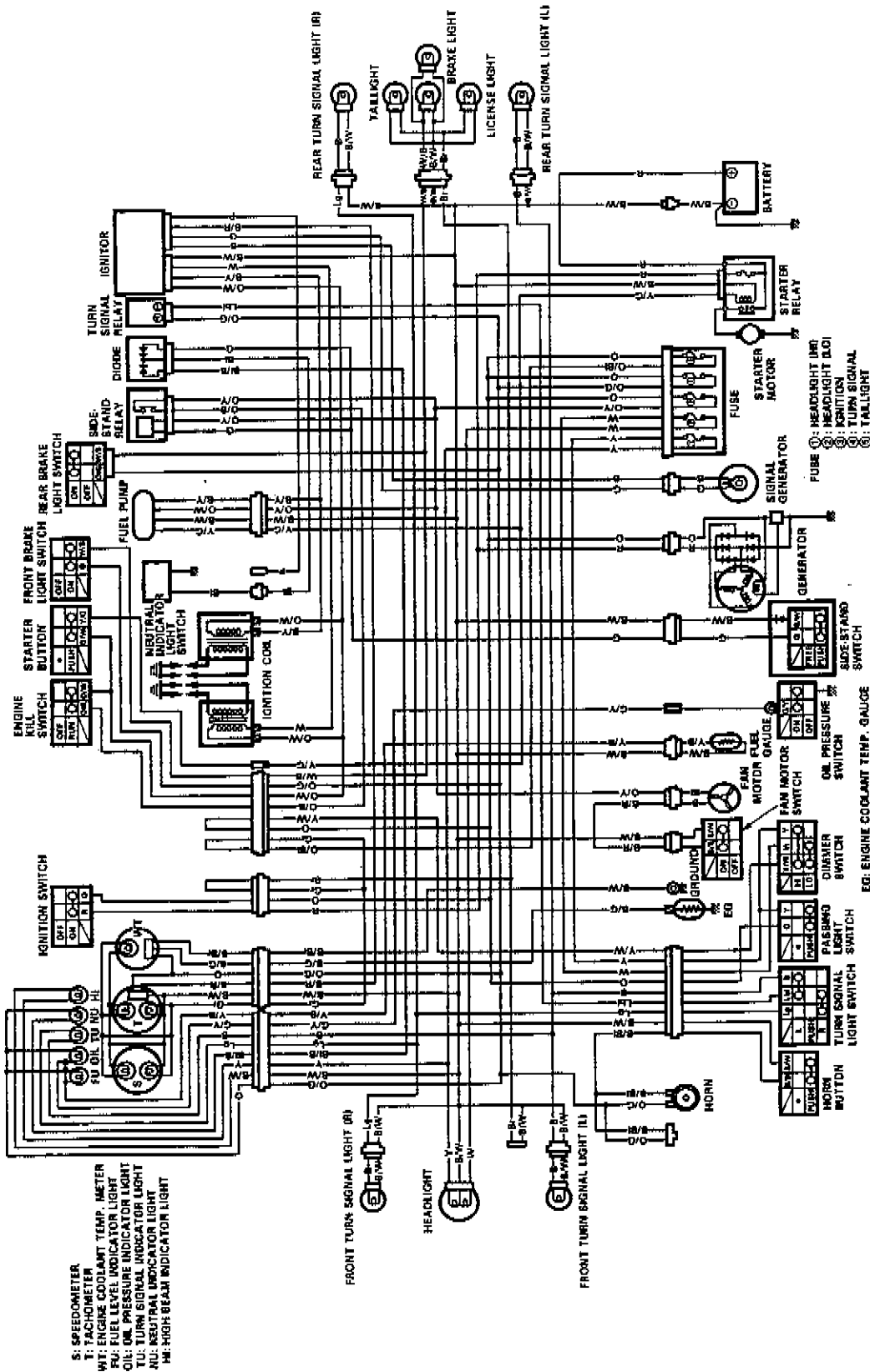

S: SPEEDOMETER
 T: TACHOMETER
 WT: ENGINE COOLANT TEMP. METER
 FL: FUEL LEVEL INDICATOR LIGHT
 OL: OIL PRESSURE INDICATOR LIGHT
 TL: TURN SIGNAL INDICATOR LIGHT
 NL: NEUTRAL INDICATOR LIGHT
 HL: HIGH BEAM INDICATOR LIGHT

WIRE COLOR

B	Black	P	Pink	B/W . . .	Black with White tracer	O/W . . .	Orange with White tracer
Bl	Blue	R	Red	B/Y . . .	Black with Yellow tracer	O/Y . . .	Orange with Yellow tracer
Br	Brown	W	White	Bl/B . . .	Blue with Black tracer	W/B . . .	White with Black tracer
G	Green	Y	Yellow	G/Y . . .	Green with Yellow tracer	Y/B . . .	Yellow with Black tracer
Gr	Gray	B/Br . . .	Black with Brown tracer	O/B . . .	Orange with Blue tracer	Y/G . . .	Yellow with Green tracer
Lbt	Light blue	B/G . . .	Black with Green tracer	O/Bl . . .	Orange with Black tracer	Y/W . . .	Yellow with White tracer
Lg	Light green	B/Bl . . .	Black with Blue tracer	O/G . . .	Orange with Green tracer		
O	Orange	B/R . . .	Black with Red tracer	O/R . . .	Orange with Red tracer		

FUSE ①: HEADLIGHT DIM
 ②: HEADLIGHT LOI
 ③: IGNITION
 ④: TURN SIGNAL
 ⑤: TAILLIGHT

EG: ENGINE COOLANT TEMP. GAUGE

B-11 SERVICING INFORMATION

For The others

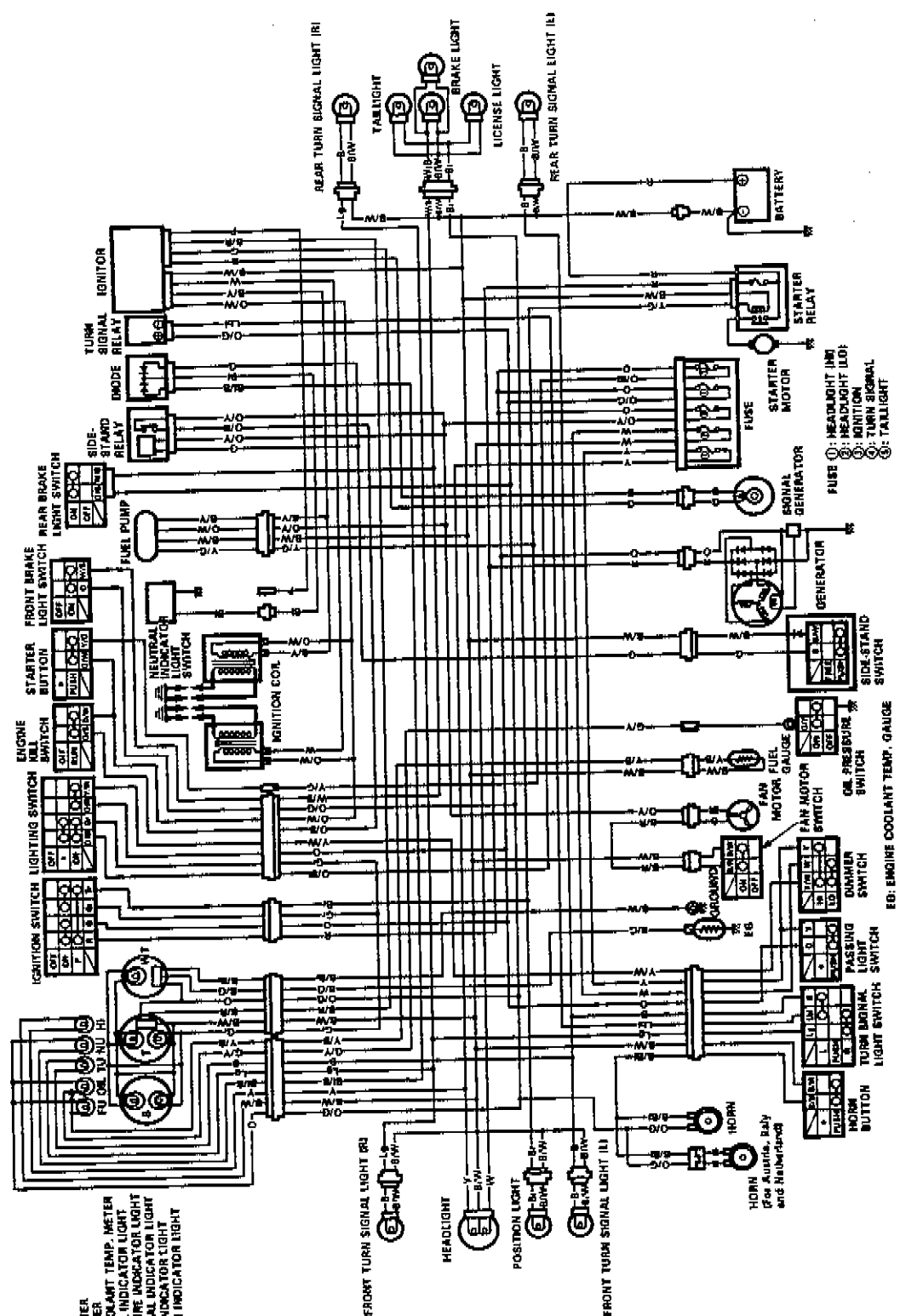

S: SPEEDOMETER
 T: TACHOMETER
 WT: ENGINE COOLANT TEMP. METER
 FL: FUEL LEVEL INDICATOR LIGHT
 OIL: OIL PRESSURE INDICATOR LIGHT
 TU: TURN SIGNAL INDICATOR LIGHT
 NI: NEUTRAL INDICATOR LIGHT
 MR: HIGH BEAM INDICATOR LIGHT

WIRE COLOR

- | | | | |
|-----|-------------|-----|---------------------------|
| B | Black | O/W | Orange with White tracer |
| Bl | Blue | O/Y | Orange with Yellow tracer |
| Br | Brown | W/B | White with Black tracer |
| G | Green | Y/B | Yellow with Black tracer |
| Gr | Gray | Y/G | Yellow with Green tracer |
| Lbl | Light blue | Y/W | Yellow with White tracer |
| Lg | Light green | | |
| O | Orange | | |
-
- | | |
|------|--------------------------|
| B/W | Black with White tracer |
| B/Y | Black with Yellow tracer |
| Bl/B | Blue with Black tracer |
| G/Y | Green with Yellow tracer |
| O/B | Orange with Black tracer |
| O/Bl | Orange with Blue tracer |
| O/G | Orange with Green tracer |
| O/R | Orange with Red tracer |
-
- | | |
|------|-------------------------|
| P | Pink |
| R | Red |
| W | White |
| Y | Yellow |
| B/Br | Black with Brown tracer |
| B/G | Black with Green tracer |
| B/Bl | Black with Blue tracer |
| B/R | Black with Red tracer |

EG: ENGINE COOLANT TEMP. GAUGE

FUSE
 ① HEADLIGHT (RM)
 ② HEADLIGHT (LD)
 ③ IGNITION
 ④ TURN SIGNAL
 ⑤ TAILLIGHT

HORN
 (For Audible, Bely
 and Numerical)

8-13 SERVICING INFORMATION

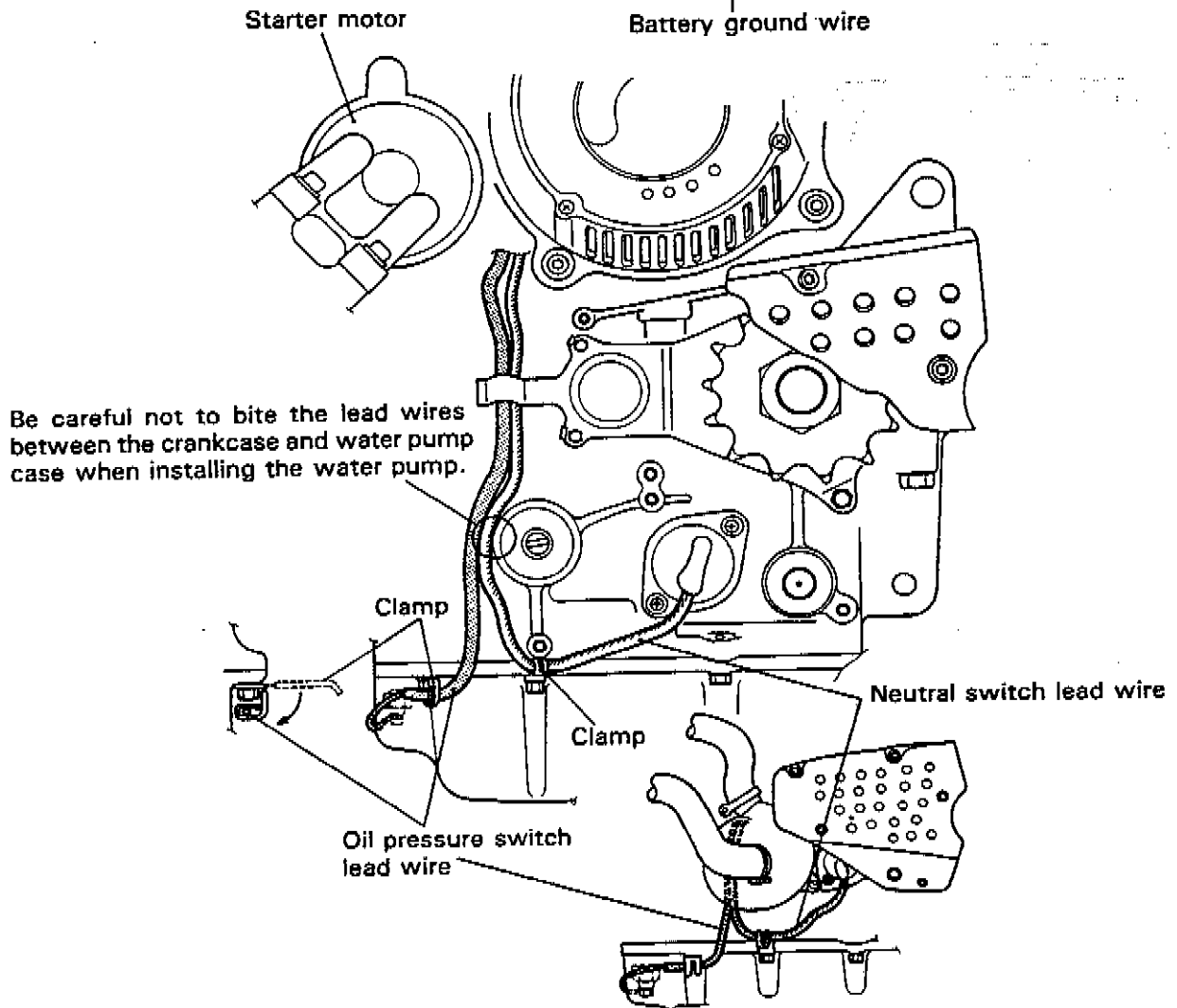
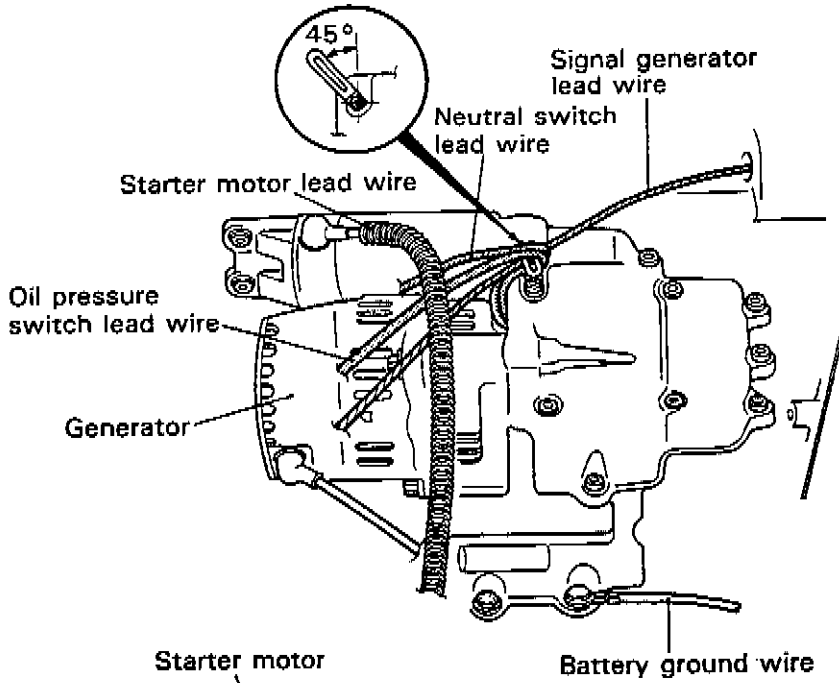

HIGH-TENSION CORD ROUTING

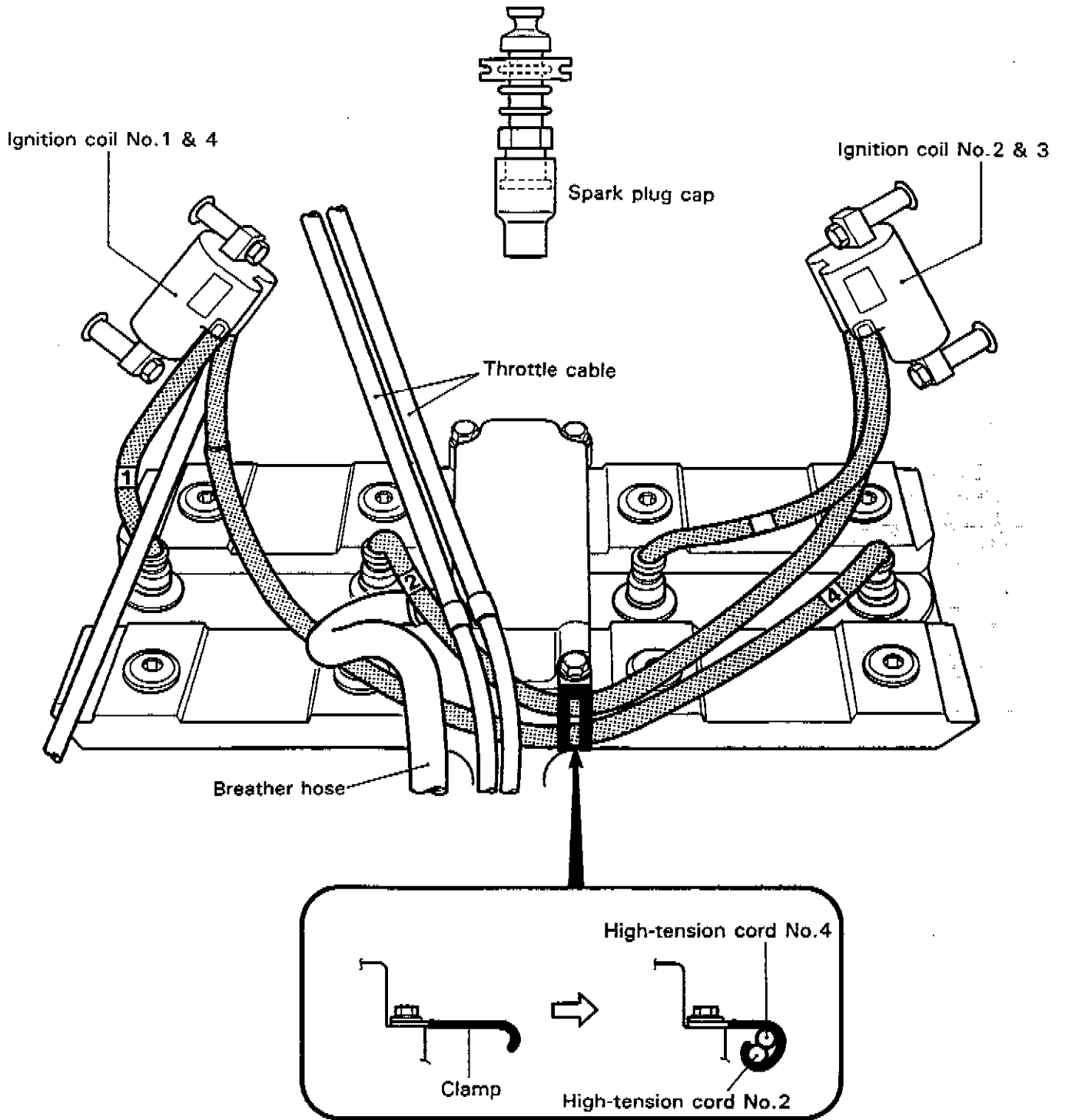

8-15 SERVICING INFORMATION

CABLE ROUTING

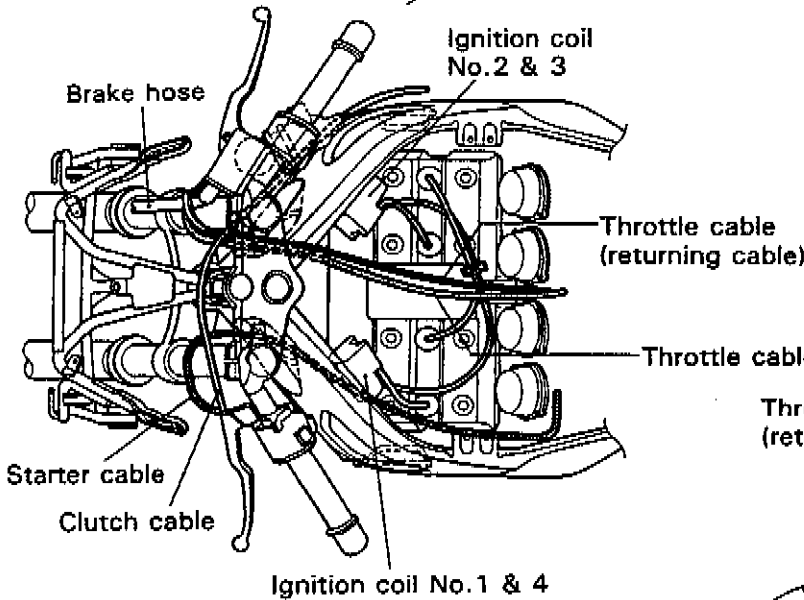
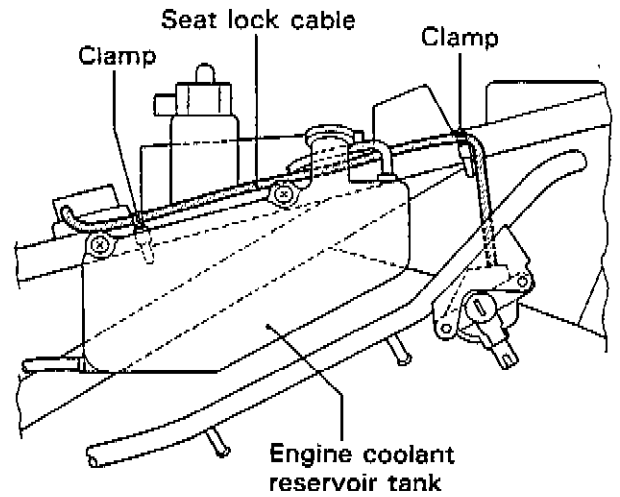
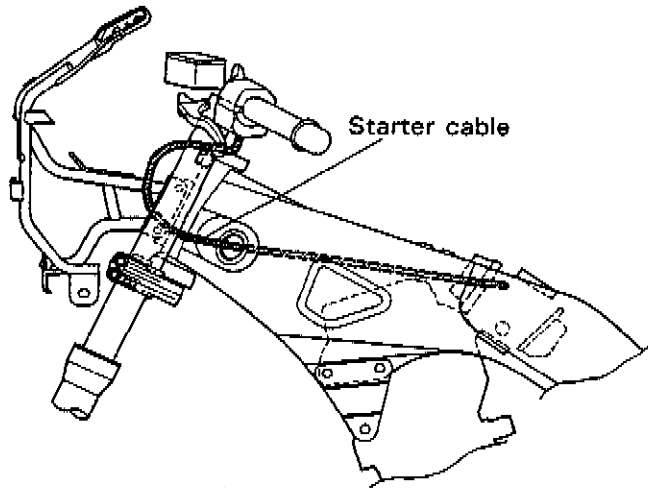

Pass through the throttle cables outside the brake hose.

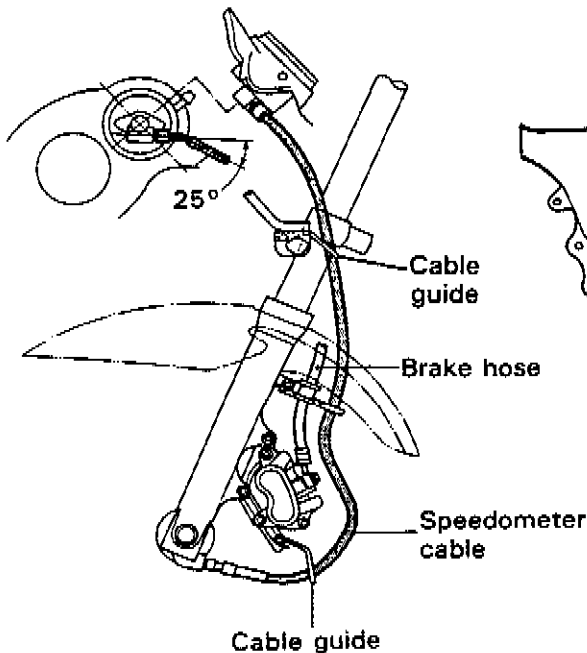
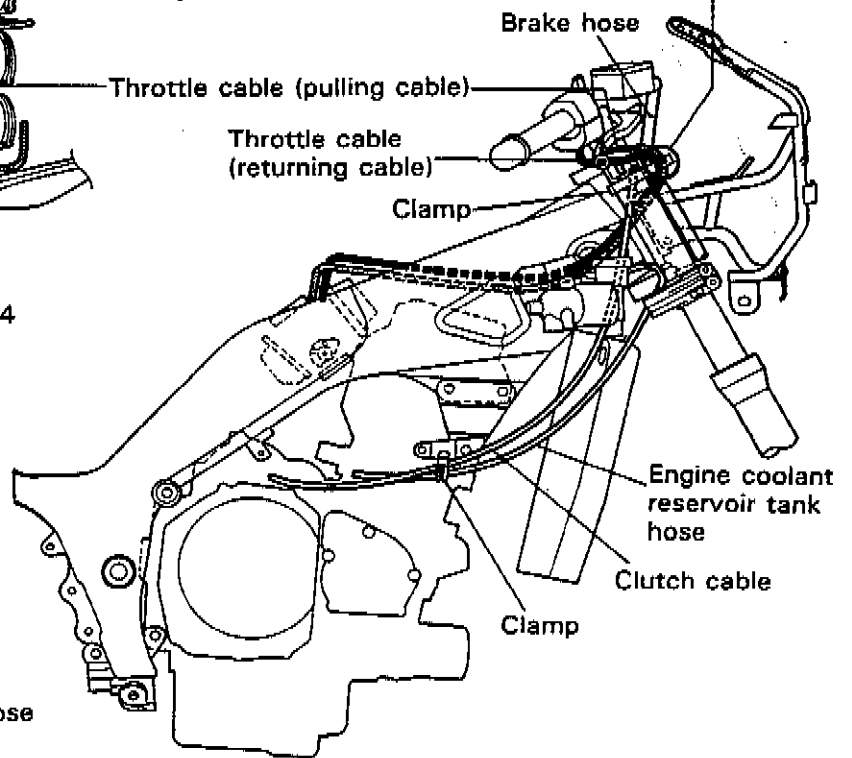

FUEL SYSTEM HOSE ROUTING

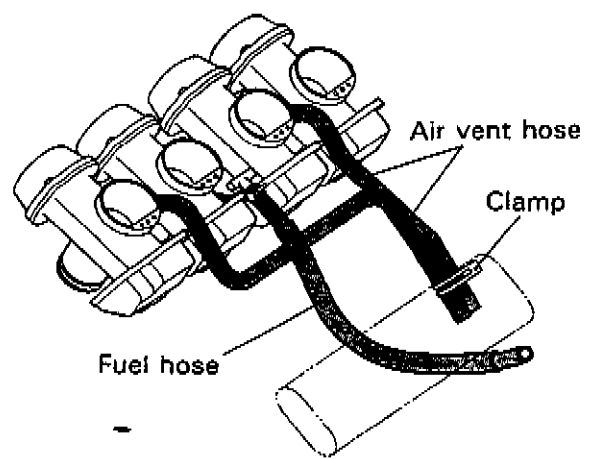
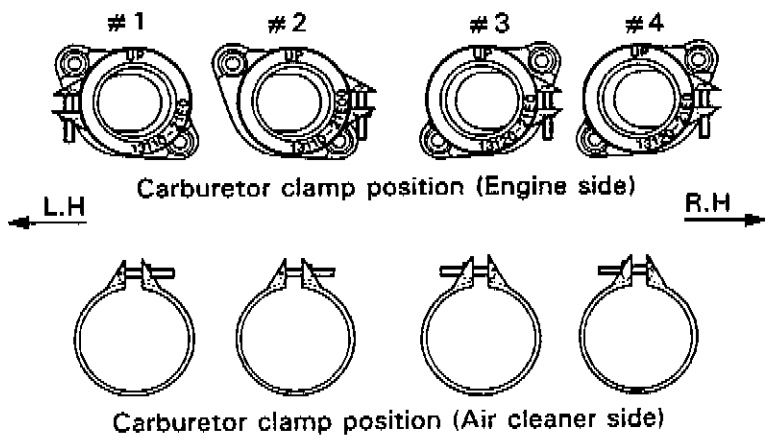
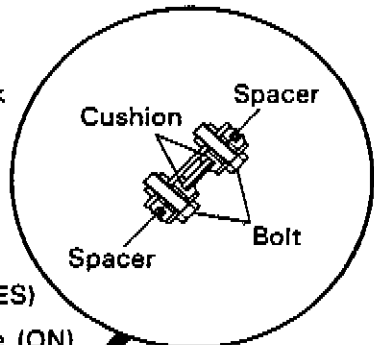
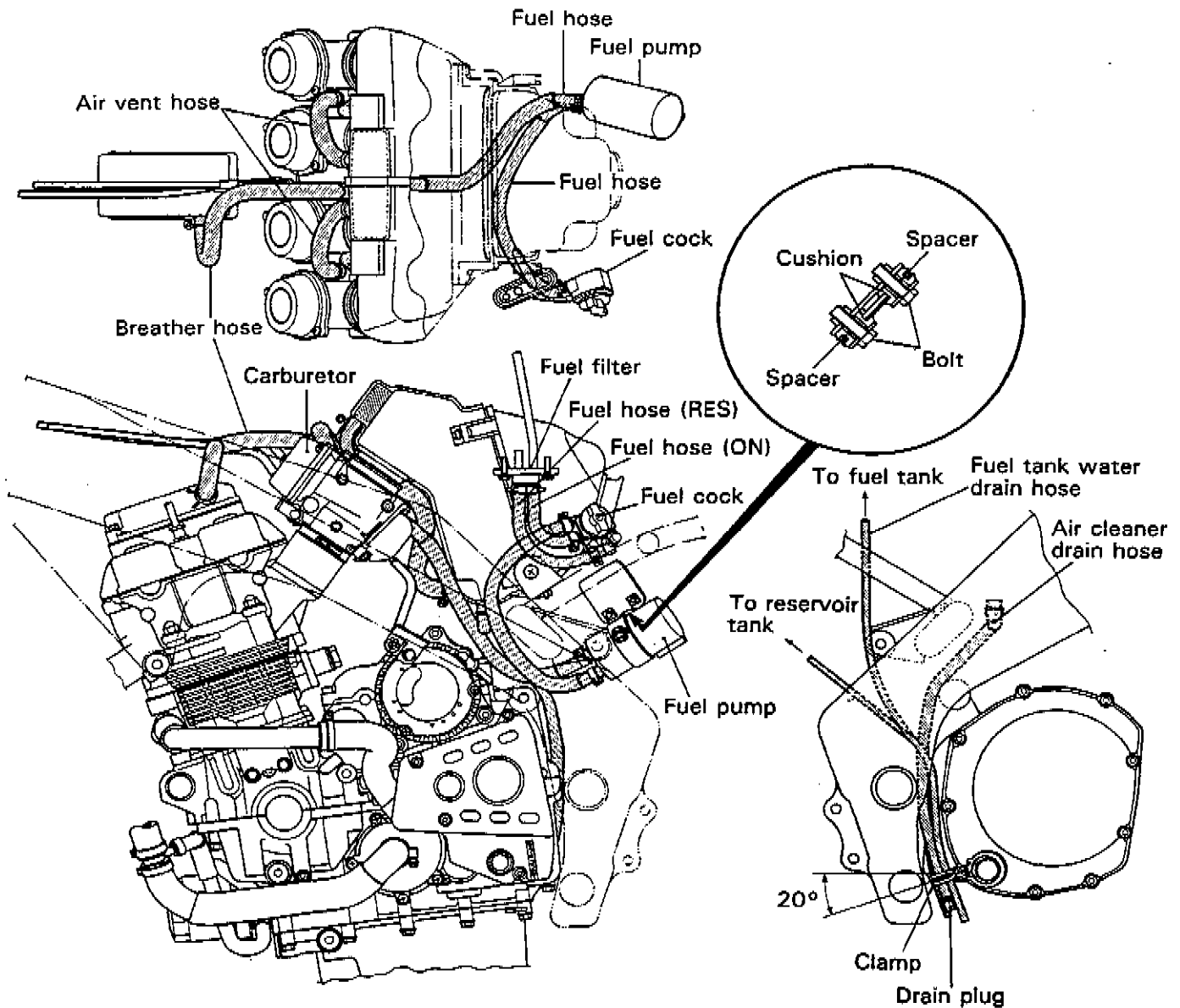

8-17 SERVICING INFORMATION

OIL HOSE ROUTING

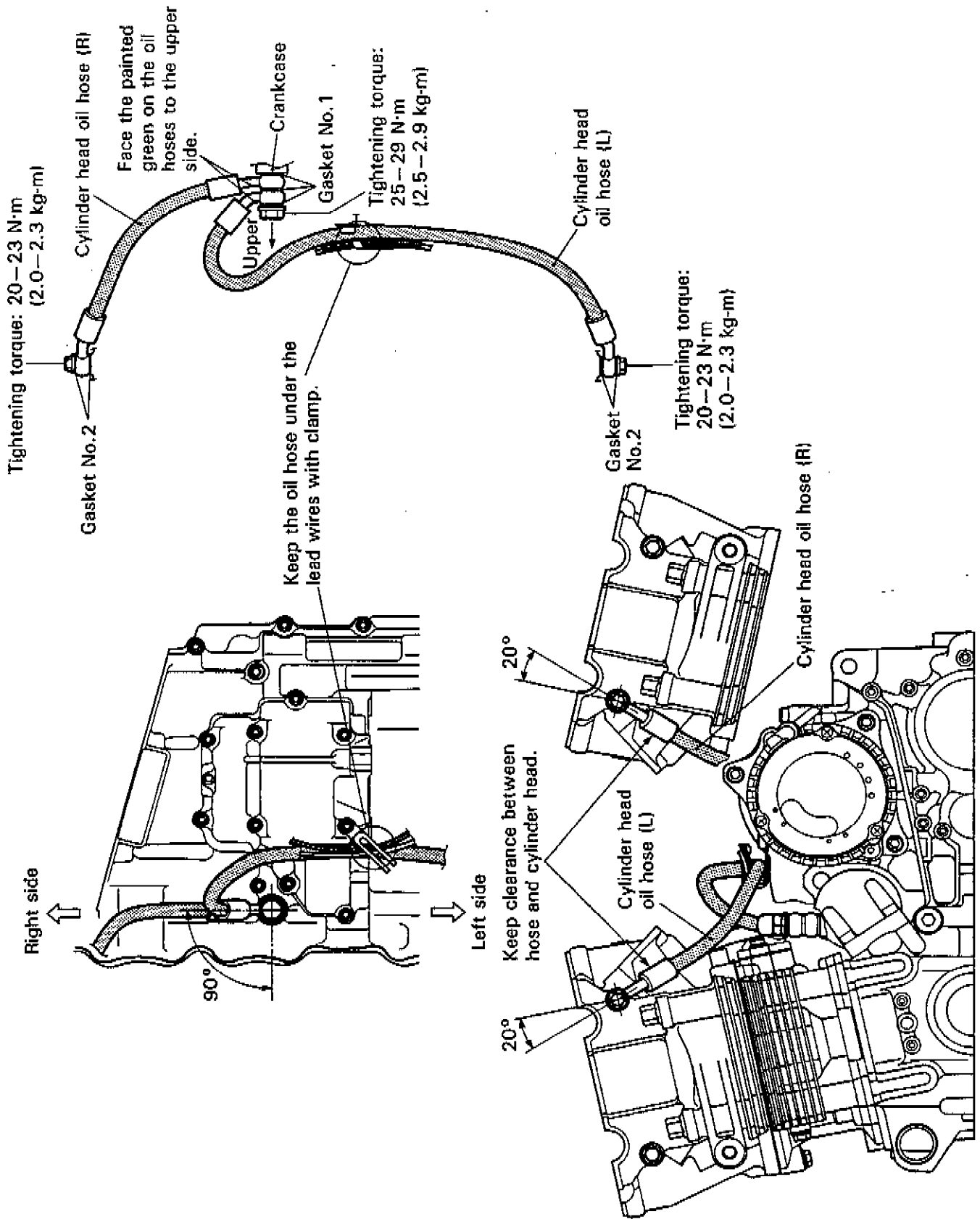

COOLING SYSTEM HOSE ROUTING

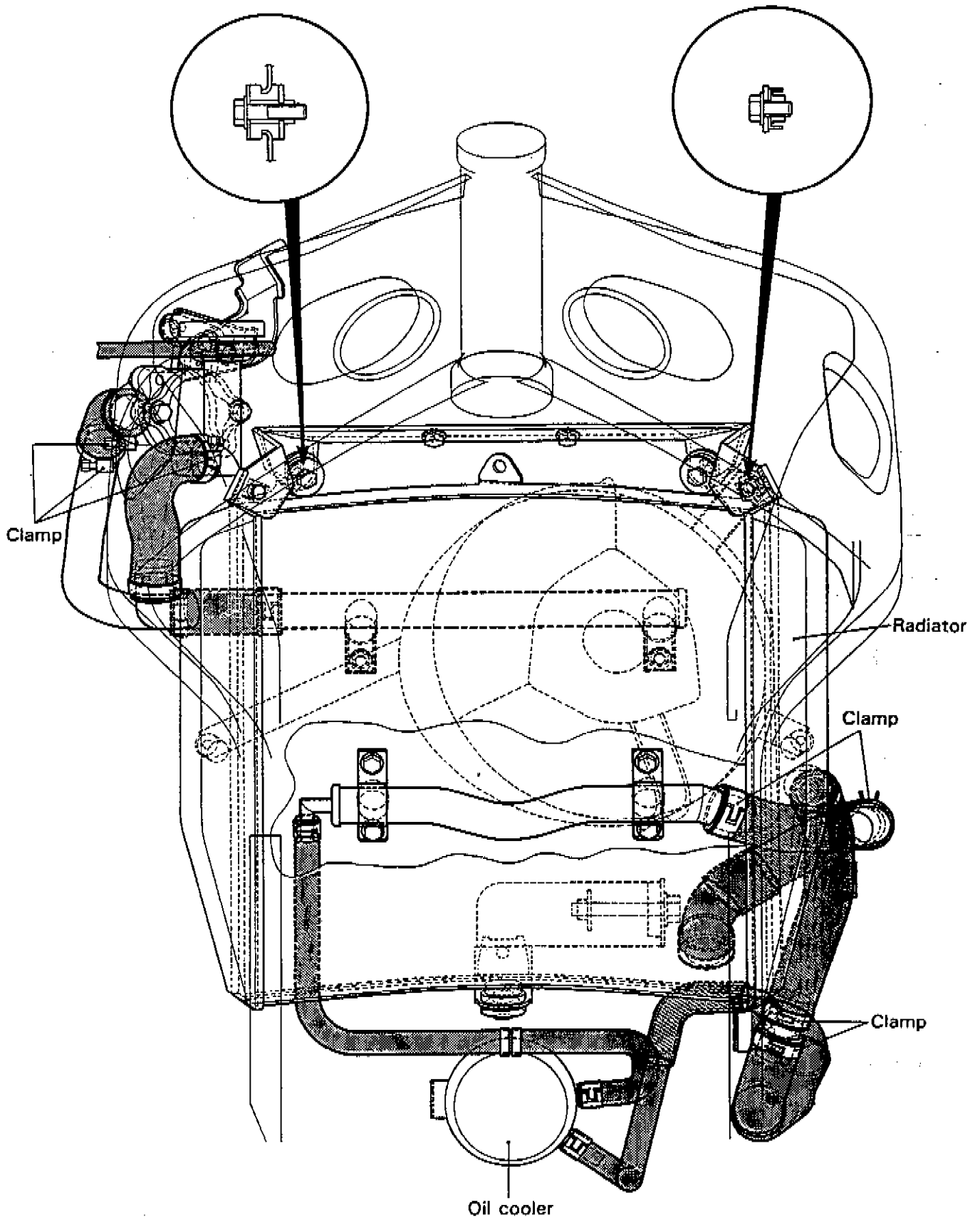

FRONT BRAKE HOSE ROUTING

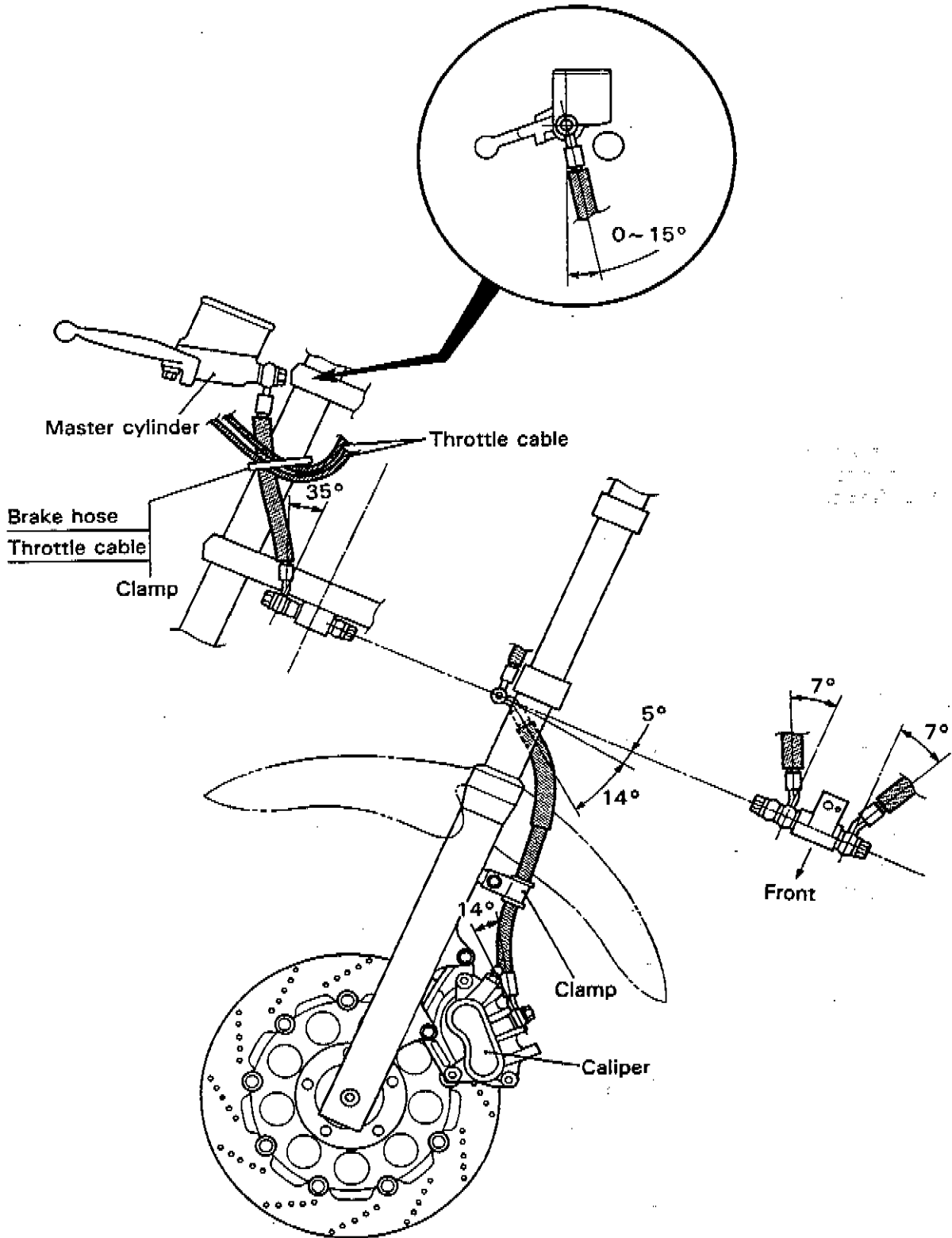

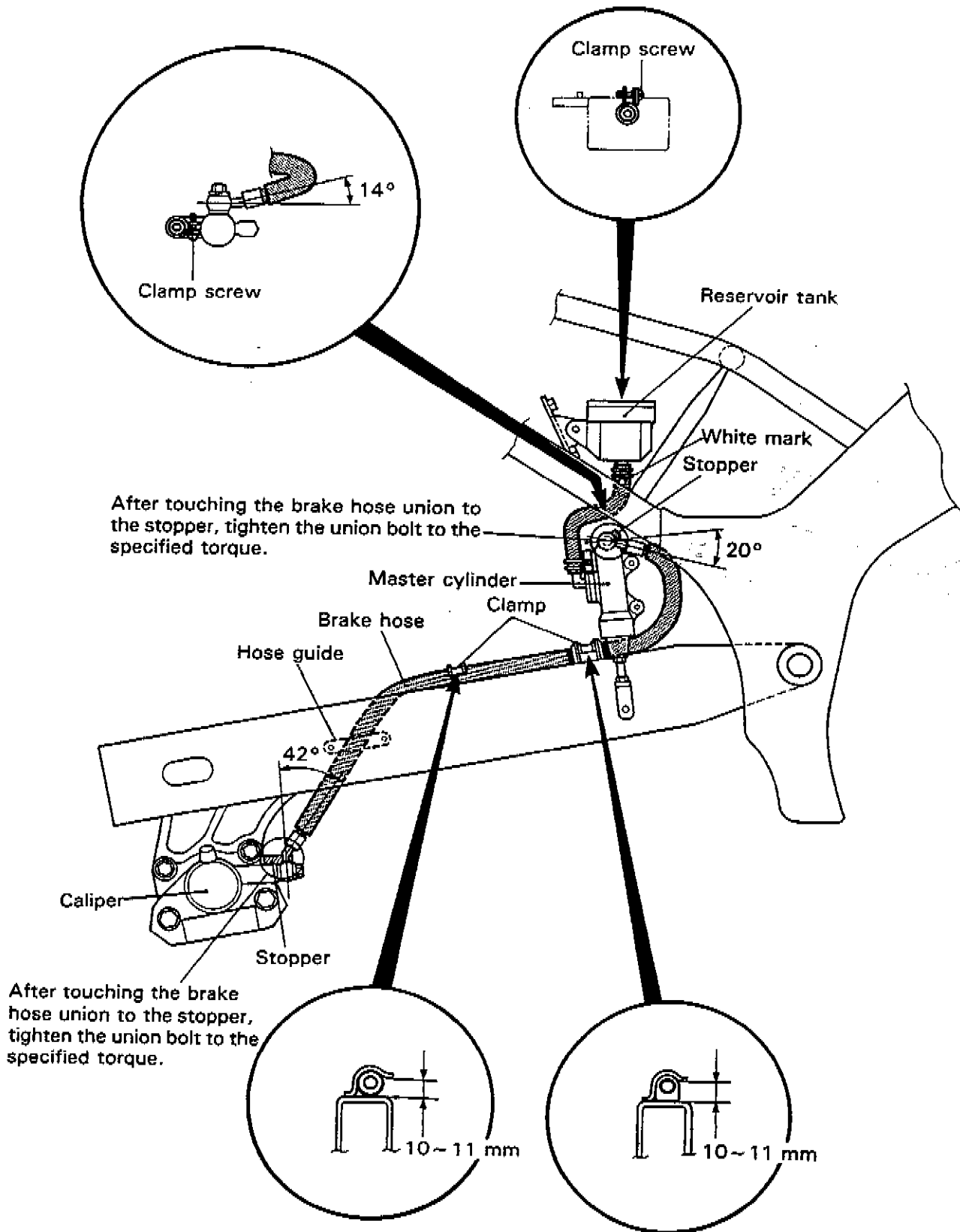
B-21 SERVICING INFORMATION**REAR BRAKE HOSE ROUTING**

PAIR (AIR SUPPLY) SYSTEM HOSE ROUTING (For California model)

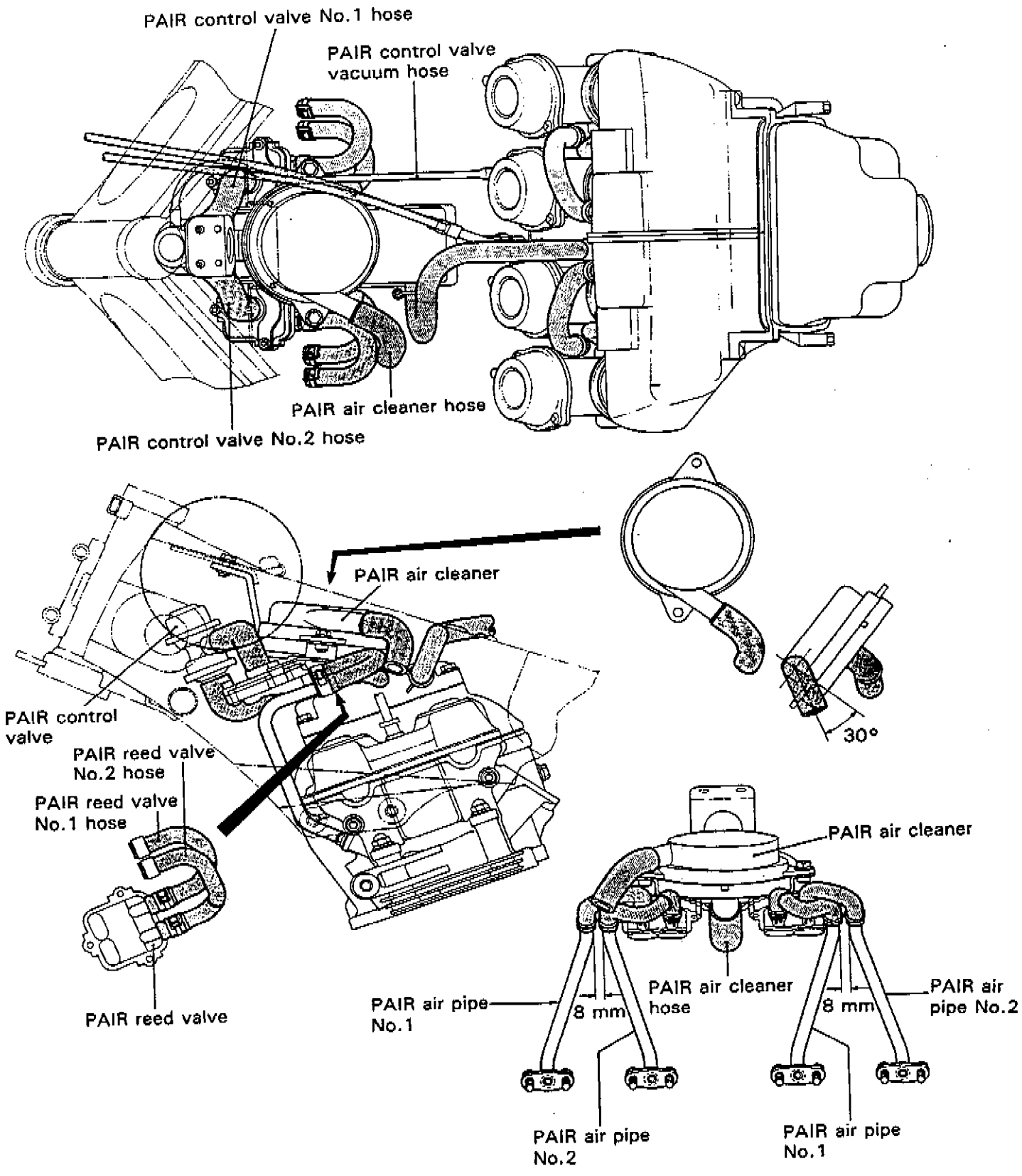

8-23 SERVICING INFORMATION

COWLING AND FRAME COVER SET UP

COWLING SET UP

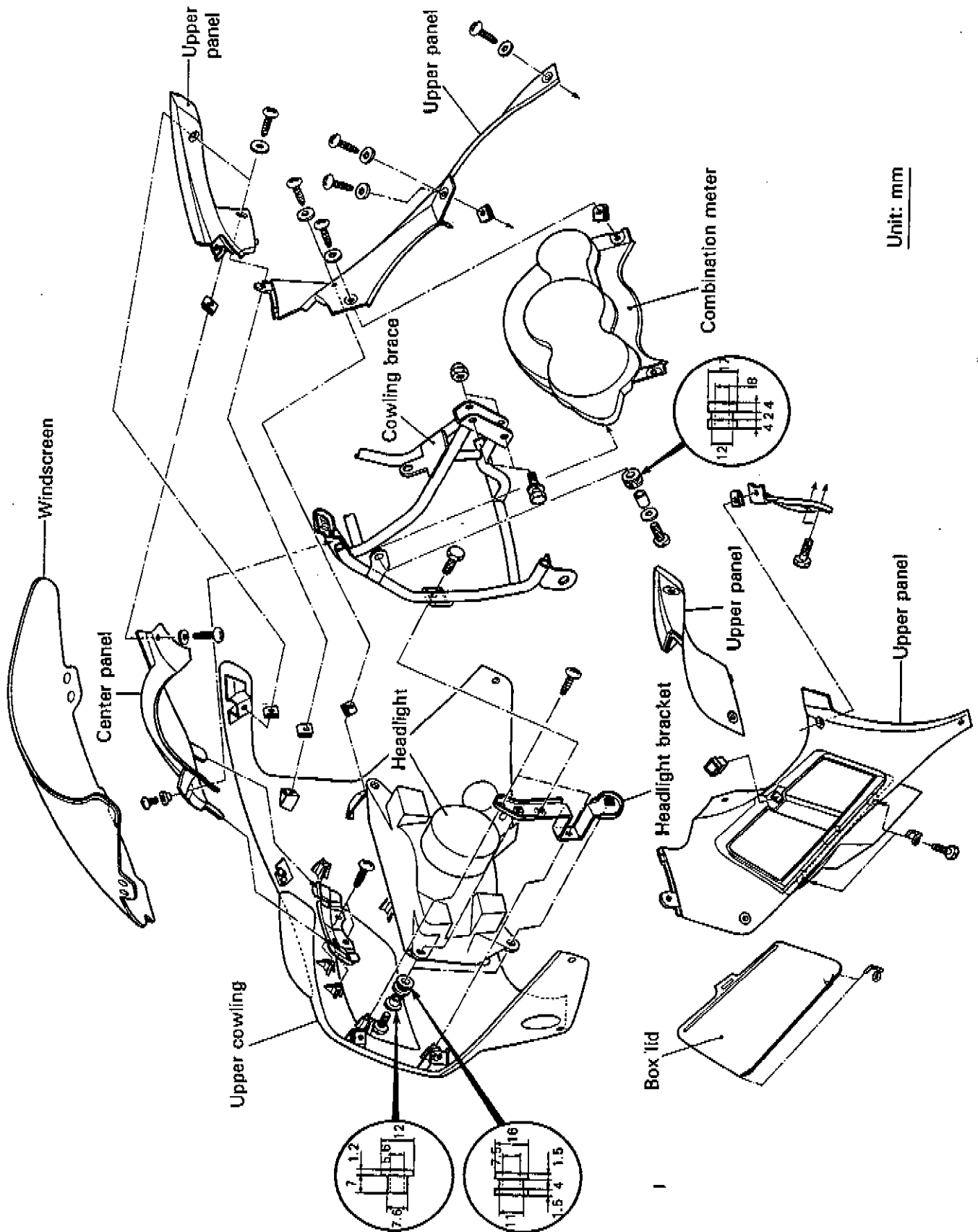

SERVICING INFORMATION 8-24

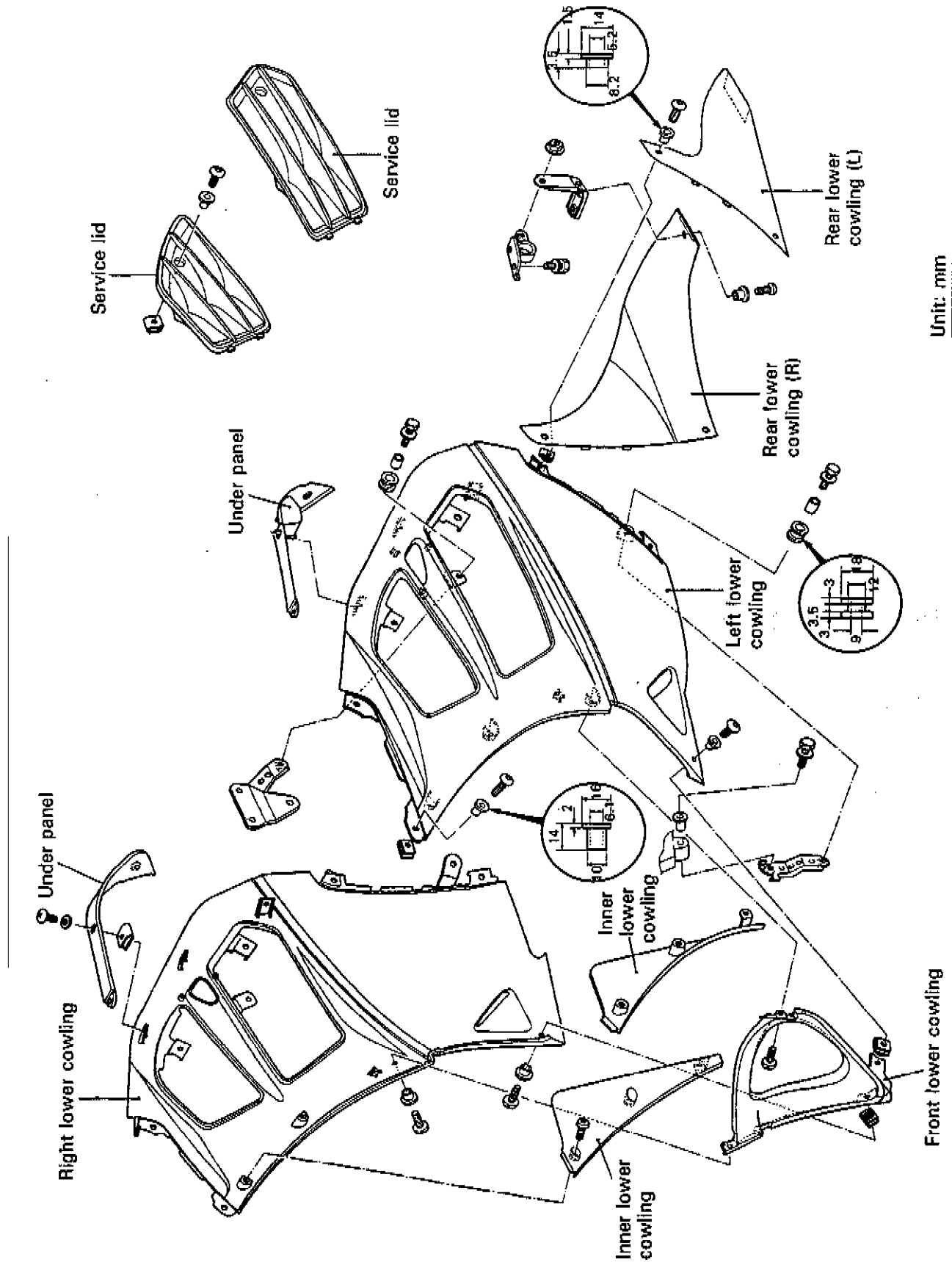

Unit: mm

B-25 SERVICING INFORMATION

FRAME COVER SET UP

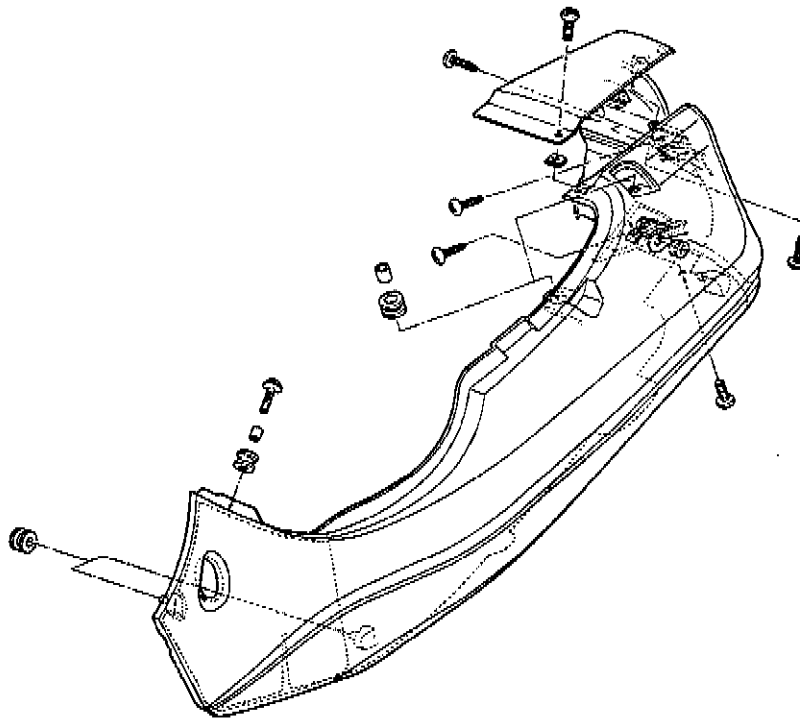



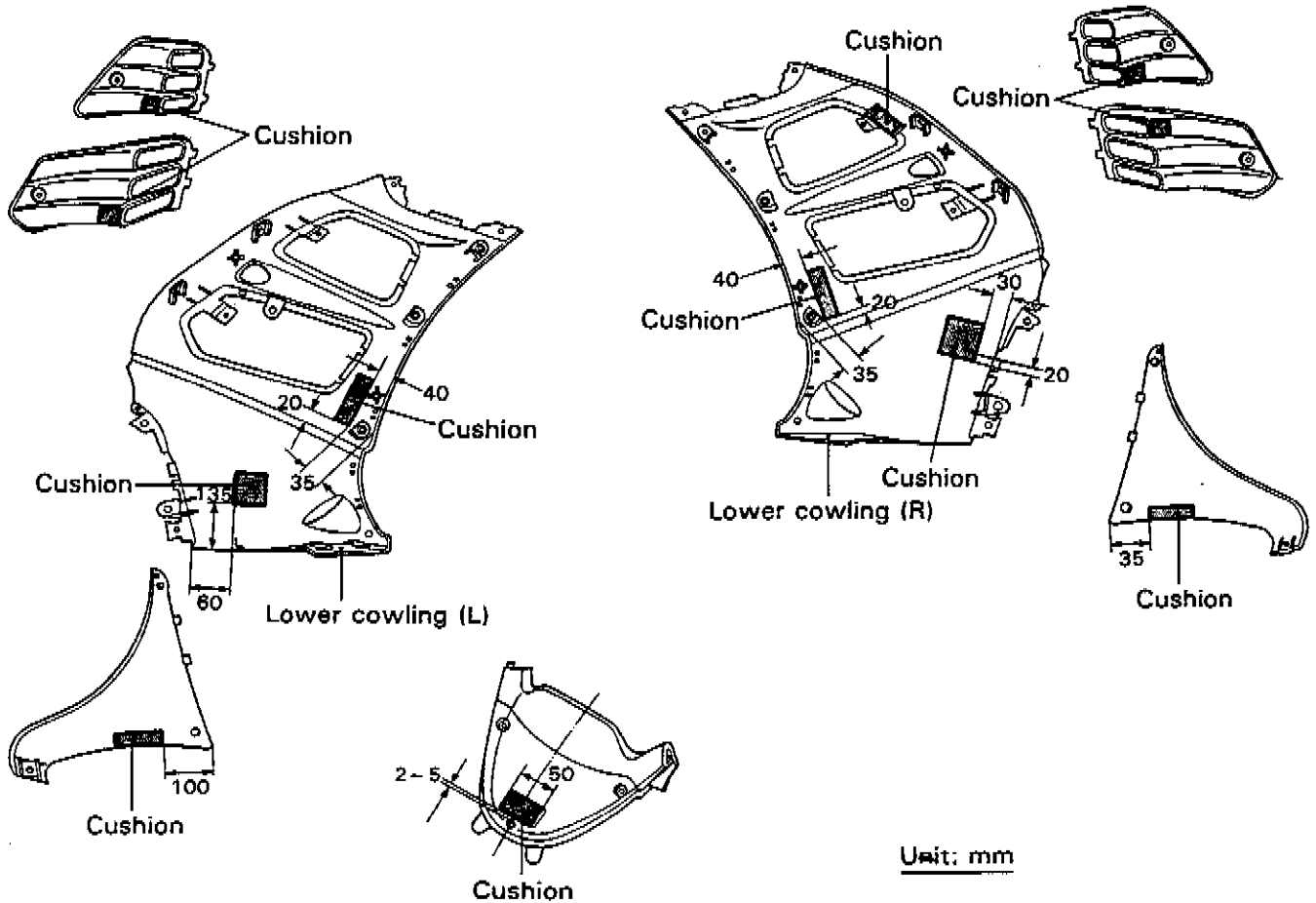







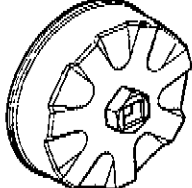

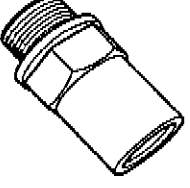
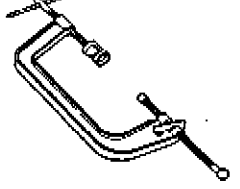
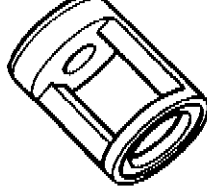
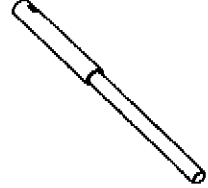
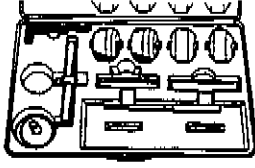





LOWER COWLING CUSHION



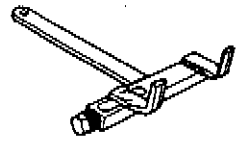

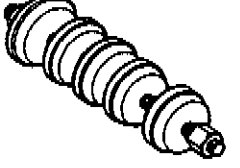
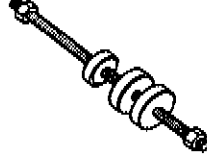
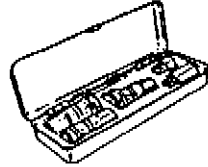
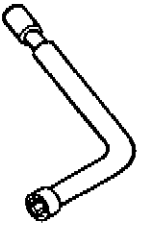

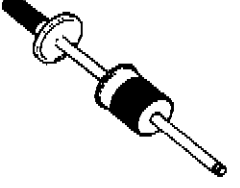
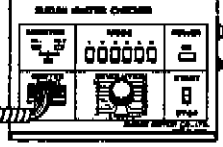
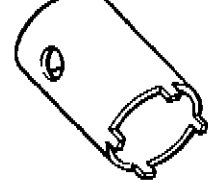
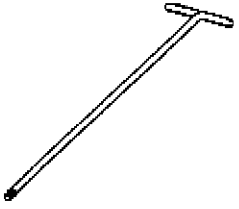
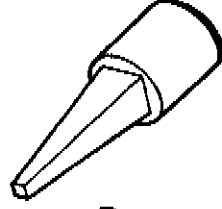
SPECIAL TOOLS

 09900-00401 "L" type hexagon wrench set	 09900-00410 Hexagon wrench set	 09900-06105 Snap ring pliers	 09900-06107 Snap ring pliers	 09900-06108 Snap ring pliers
 09900-09003 Impact driver set	 09900-20102 Vernier calipers (1/20 mm, 200 mm)	 09900-20202 Micrometer (1/100 mm, 25–50 mm)	 09900-20203 Micrometer (1/100 mm, 50–75 mm)	 09900-20205 Micrometer (1/1000 mm, 0–25 mm)
 09900-20508 Cylinder gauge set (1/100 mm, 40–80 mm)	 09900-20602 Dial gauge (1/1000 mm, 1 mm)	 09900-20605 Dial calipers (1/100 mm, 10–34 mm)	 09900-20606 Dial gauge (1/100 mm, 10 mm)	 09900-20701 Magnetic stand
 09900-20803 Thickness gauge	 09900-20805 Tire depth gauge	 09900-21304 V-block set (100 mm)	 09900-22301 Plastigauge	 09900-22401 Small bore gauge (10–18 mm)
 09900-25002 Pocket tester	 09900-28106 Electro tester	 09910-20116 Con-rod holder	 09911-73730 "T" type hexagon wrench (5 mm)	 09911-74520 Long socket (12 mm)
 09913-13121 Carburetor balancer	 09913-60910 Bearing puller (40–60 mm)	 09913-75520 Bearing installer	 09914-24510 T-handle	 09914-25811 "T" type hexagon wrench (6 mm)

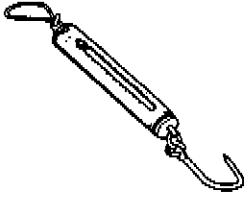
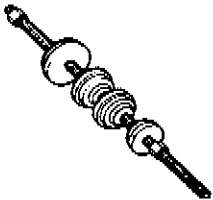
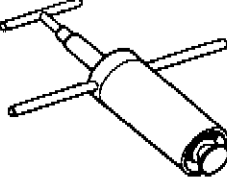
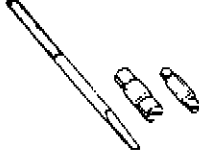
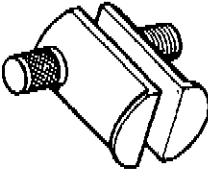
8-27 SERVICING INFORMATION

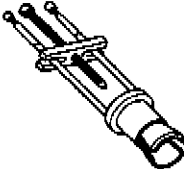
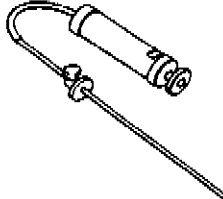
				
09915-40610 Oil filter wrench	09915-64510 Compression gauge 09915-63310 (Adaptor)	09915-74510 Oil pressure gauge 09915-77330 (for high pressure meter)	09915-74540 Oil pressure gauge adaptor	09916-14510 Valve lifter
				
09916-14520 Valve lifter attach- ment	09916-20640 Solid pilot (N-100-4.5)	09916-21110 Valve seat cutter set	See page 3-24. Valve seat cutter head (N-111, 116, 120, 121, 122,126)	09916-33210 Valve guide reamer (4.5 mm)
				
09916-34542 Valve guide reamer handle	09916-34580 Valve guide reamer (10.8 mm)	09916-43210 Valve guide remover/ installer	09916-43230 Attachment	09916-74521 Piston ring com- pressor body
				
09916-74540 Piston ring com- pressor band (63-75 mm)	09916-84511 Tweezers	09920-53740 Clutch sleeve hub holder	09923-73210 Bearing puller (17-20 mm)	09924-84510 Bearing installer set
				
09924-84521 Bearing installer	09930-10121 Spark plug socket wrench set	09930-11910 Torx wrench	09930-14530 Universal joint	09930-30102 Sliding shaft
				
09931-94430 Ignitor checker (Digital type)	09940-14911 Steering stem nut wrench	09940-34520 "T" handle	09940-34561 Attachment "D"	09940-50113 Front fork oil seal installer

 <p>09940-92710 Spring scale</p>	 <p>09941-34513 Steering outer race installer</p>	 <p>09941-44510 Swingarm bearing remover</p>	 <p>09941-50111 Bearing remover</p>	 <p>09941-54911 Bearing outer race remover</p>
 <p>09941-74910 Steering bearing installer</p>	 <p>09941-84510 Bearing remover</p>	 <p>09943-74111 Front fork oil level gauge</p>	 <p>09951-16080 Bearing installer</p>	

NOTE:

When ordering the special tool, please confirm whether it is available or not.

B-29 SERVICING INFORMATION**TIGHTENING TORQUE****ENGINE**

ITEM	N-m	kg-m	lb-ft
Cylinder head cover bolt	13-15	1.3-1.5	9.5-11.0
Cylinder head bolt [M: 10]	40-45	4.0-4.5	29.0-32.5
Cylinder head bolt [M: 6]	8-12	0.8-1.2	6.0-8.5
Cylinder base nut	7-11	0.7-1.1	5.0-8.0
Camshaft journal holder bolt	8-12	0.8-1.2	6.0-8.5
Cam sprocket bolt	24-26	2.4-2.6	17.5-19.0
Oil hose mounting bolt [Cylinder side]	20-23	2.0-2.3	14.5-16.5
Oil hose mounting bolt [Crankcase side]	25-29	2.5-2.9	18.0-21.0
Cam chain tensioner mounting bolt	6-8	0.6-0.8	4.5-6.0
Cam chain tensioner spring holder bolt	30-40	3.0-4.0	21.5-29.0
Conrod bearing cap bolt	65-68	6.5-6.8	47.0-49.0
Starter clutch bolt	23-28	2.3-2.8	16.5-20.0
Signal generator bolt	23-26	2.3-2.6	16.5-19.0
Crankcase bolt [M: 6]	12-16	1.2-1.6	8.5-16.5
[M: 8] [M: 9]	24-28	2.4-2.8	17.5-20.0
Oil pump mounting bolt	8-12	0.8-1.2	6.0-8.5
Oil drain plug	20-25	2.0-2.5	14.5-18.0
Oil pan bolt	12-16	1.2-1.6	8.5-11.5
Gearshift cam stopper bolt	8-12	0.8-1.2	6.0-8.5
Gearshift cam stopper plate bolt	8-12	0.8-1.2	6.0-8.5
Gearshift arm stopper bolt	15-23	1.5-2.3	11.0-16.5
Clutch sleeve hub nut	80-100	8.0-10.0	58.0-72.5
Clutch spring bolt	11-13	1.1-1.3	8.0-9.5
Exhaust pipe bolt	18-28	1.8-2.8	13.0-20.0
Muffler mounting bolt	18-28	1.8-2.8	13.0-20.0
Engine sprocket nut	100-130	10.0-13.0	72.5-94.0
Engine mounting bolt [L: 30]	50-60	5.0-6.0	36.0-43.5
[L: 140 and 280]	70-88	7.0-8.8	50.5-63.5
Starter clutch shaft nut	80-100	8.0-10.0	58.0-72.5
Generator driven gear nut	40-60	4.0-6.0	29.0-43.5
Generator mounting bolt	21-29	2.1-2.9	15.0-21.0
Oil cooler mounting bolt	53-64	5.3-6.4	38.5-46.5
Oil pressure regulator	25-30	2.5-3.0	18.0-21.5
Oil pressure switch	12-15	1.2-1.5	8.5-11.0
Oil gallery plug [M: 16]	35-45	3.5-4.5	25.5-32.5
[M: 14]	25-30	2.5-3.0	18.0-21.5
[M: 10]	12-18	1.2-1.8	8.5-13.0
Crankcase plug [M: 22]	35-45	3.5-4.5	25.5-32.5
[M: 18]	25-30	2.5-3.0	18.0-21.5
Cooling fan thermo-switch	9-14	0.9-1.4	6.5-10.0

SERVICING INFORMATION 8-30**CHASSIS**

ITEM	N·m	kg-m	lb-ft
Steering stem head nut	80-100	8.0-10.0	58.0-72.5
Front fork upper clamp bolt	18-28	1.8-2.8	13.0-20.0
Front fork lower clamp bolt	18-28	1.8-2.8	13.0-20.0
Front fork cap bolt	30-40	3.0-4.0	21.5-29.0
Front fork damper rod bolt	18-27	1.8-2.7	13.0-19.5
Front axle	50-80	5.0-8.0	36.0-58.0
Front axle pinch bolt	18-28	1.8-2.8	13.0-20.0
Handlebar set bolt	18-28	1.8-2.8	13.0-20.0
Handlebar holder mounting bolt and nut	22-35	2.2-3.5	16.0-25.5
Front brake master cylinder mounting bolt	8-12	0.8-1.2	6.0-8.5
Front brake caliper mounting bolt	20-30	2.0-3.0	14.5-21.5
Front brake caliper pad mounting bolt	15-20	1.5-2.0	11.0-14.5
Brake hose union bolt (Front & Rear)	15-20	1.5-2.0	11.0-14.5
Air bleeder valve (Front & Rear)	6-9	0.6-0.9	4.5-6.5
Brake disc bolt (Front & Rear)	18-28	1.8-2.8	13.0-20.0
Front footrest bracket mounting bolt	18-28	1.8-2.8	13.0-20.0
Front footrest nut	42-66	4.2-6.6	30.5-47.5
Swingarm pivot nut	85-115	8.5-11.5	61.5-83.0
Rear shock absorber mounting nut (Upper & Lower)	40-60	4.0-6.0	29.0-43.5
Rear cushion lever/rod mounting nut	70-100	7.0-10.0	50.5-72.5
Rear brake caliper mounting bolt	20-30	2.0-3.0	14.5-21.5
Rear brake caliper housing bolt	30-36	3.0-3.6	21.5-26.0
Rear brake master cylinder mounting bolt	18-28	1.8-2.8	13.0-20.0
Rear brake master cylinder rod lock nut	15-20	1.5-2.0	11.0-14.5
Rear axle nut	85-115	8.5-11.5	61.5-83.0
Rear sprocket nut	48-72	4.8-7.2	35.0-52.0

8-31 SERVICING INFORMATION**TIGHTENING TORQUE CHART**

For other bolts and nuts listed previously, refer to this chart:

Bolt Diameter Ⓐ (mm)	Conventional or "4" marked bolt			"7" marked bolt		
	N·m	kg·m	lb·ft	N·m	kg·m	lb·ft
4	1.0–2.0	0.1–0.2	0.7–1.5	1.5–3.0	0.15–0.3	1.0–2.0
5	2.0–4.0	0.2–0.4	1.5–3.0	3.0–6.0	0.3–0.6	2.0–4.5
6	4.0–7.0	0.4–0.7	3.0–5.0	8.0–12.0	0.8–1.2	6.0–8.5
8	10.0–16.0	1.0–1.6	7.0–11.5	18.0–28.0	1.8–2.8	13.0–20.0
10	22.0–35.0	2.2–3.5	16.0–25.5	40.0–60.0	4.0–6.0	29.0–43.5
12	35.0–55.0	3.5–5.5	25.5–40.0	70.0–100.0	7.0–10.0	50.5–72.5
14	50.0–80.0	5.0–8.0	36.0–58.0	110.0–160.0	11.0–16.0	79.5–115.5
16	80.0–130.0	8.0–13.0	58.0–94.0	170.0–250.0	17.0–25.0	123.0–181.0
18	130.0–190.0	13.0–19.0	94.0–137.5	200.0–280.0	20.0–28.0	144.5–202.5

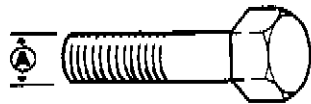

Conventional bolt

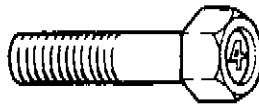

"4" marked bolt

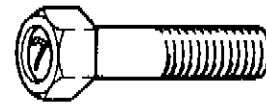

"7" marked bolt

SERVICE DATA

VALVE + GUIDE

Unit: mm (in)

ITEM	STANDARD		LIMIT
Valve diam.	IN.	25.5 (1.00)	—
	EX.	22.5 (0.89)	—
Valve lift	IN.	E-04 and others 8.3 (0.33)	—
		E-18 6.6 (0.26)	—
	EX.	E-04 and others 7.9 (0.31)	—
		E-18 6.1 (0.24)	—
Tappet clearance (when cold)	IN.	0.10–0.20 (0.004–0.008)	—
	EX.	0.20–0.30 (0.008–0.010)	—
Valve guide to valve stem clearance	IN.	0.020–0.047 (0.0008–0.0019)	—
	EX.	0.030–0.057 (0.0012–0.0022)	—
Valve stem deflection	IN. & EX.	—	0.35 (0.014)
Valve guide I.D.	IN. & EX.	4.500–4.512 (0.1772–0.1776)	—
Valve stem O.D.	IN.	4.465–4.480 (0.1758–0.1764)	—
	EX.	4.455–4.470 (0.1754–0.1760)	—
Valve stem runout	IN. & EX.	—	0.05 (0.002)
Valve head thickness	IN. & EX.	—	0.5 (0.02)
Valve seat width	IN. & EX.	0.9–1.1 (0.035–0.043)	—
Valve head radial runout	IN. & EX.	—	0.03 (0.001)
Valve spring free length (IN. & EX.)	—		43.0 (1.69)
Valve spring tension (IN. & EX.)	18.6–21.4 kg (41.0–47.2 lbs) at length 38 mm (1.5 in)		—

8-33 SERVICING INFORMATION**CAMSHAFT + CYLINDER HEAD**

Unit: mm (in)

ITEM	STANDARD		LIMIT	
Cam height	IN.	E-04	36.312–36.368 (1.4296–1.4318)	36.02 (1.418)
		E-33	34.542–34.598 (1.3599–1.3621)	34.25 (1.348)
		E-03	36.312–36.368 (1.4296–1.4318)	36.02 (1.418)
	EX.	E-04	35.902–35.958 (1.4135–1.4157)	35.61 (1.402)
		E-33	34.122–34.178 (1.3433–1.3456)	33.83 (1.332)
		E-03	35.902–35.958 (1.4135–1.4157)	35.61 (1.402)
Camshaft journal oil clearance	IN. & EX.	0.032–0.066 (0.0013–0.0026)	0.150 (0.0059)	
Camshaft journal holder I.D.	IN. & EX.	22.012–22.025 (0.8666–0.8671)	—	
Camshaft journal O.D.	IN. & EX.	21.959–21.980 (0.8645–0.8654)	—	
Camshaft runout	IN. & EX.	—	0.10 (0.004)	
Cam chain pin (at arrow "3")	13th pin		—	
Cylinder head distortion	—		0.20 (0.008)	

CYLINDER + PISTON + PISTON RING

Unit: mm (in)

ITEM	STANDARD		LIMIT	
Compression pressure	1 000–1 500 kPa (10–15 kg/cm ²) (142–213 psi)		800 kPa (8 kg/cm ²) (114psi)	
Compression pressure difference	—		200 kPa (2 kg/cm ²) (28 psi)	
Piston to cylinder clearance	0.040–0.060 (0.0016–0.0024)		0.120 (0.0047)	
Cylinder bore	65.000–65.015 (2.5591–2.5596)		65.090 (2.5626)	
Piston diam.	64.945–64.970 (2.5569–2.5579) Measure at 15 mm (0.6 in) from the skirt end.		64.880 (2.5543)	
Cylinder distortion	—		0.20 (0.008)	
Piston ring free end gap	1st	R	Approx. 7.5 (0.29)	6.0 (0.24)
	2nd	R	Approx. 8.0 (0.31)	6.4 (0.25)
Piston ring end gap	1st		0.25–0.40 (0.010–0.016)	0.5 (0.02)
	2nd		0.25–0.40 (0.010–0.016)	0.5 (0.02)

SERVICING INFORMATION 8-34

ITEM	STANDARD		LIMIT
Piston ring to groove clearance	1st	—	0.18 (0.007)
	2nd	—	0.18 (0.007)
Piston ring groove width	1st	0.83–0.85 (0.032–0.033)	—
	2nd	0.82–0.84 (0.032–0.033)	—
	Oil	1.51–1.53 (0.059–0.060)	—
Piston ring thickness	1st	0.77–0.79 (0.030–0.031)	—
	2nd	0.77–0.79 (0.030–0.031)	—
Piston pin bore	16.002–16.008 (0.6210–0.6302)		16.030 (0.6311)
Piston pin O.D.	15.996–16.000 (0.6298–0.6299)		15.980 (0.6291)

CONROD + CRANKSHAFT

Unit: mm (in)

ITEM	STANDARD		LIMIT
Conrod small end I.D.	16.010–16.018 (0.6303–0.6306)		16.040 (0.6315)
Conrod big end side clearance	0.10–0.20 (0.004–0.008)		0.30 (0.010)
Conrod big end width	20.95–21.00 (0.825–0.827)		—
Crank pin width	21.10–21.15 (0.831–0.833)		—
Conrod big end oil clearance	0.032–0.056 (0.0013–0.0022)		0.080 (0.0031)
Crank pin O.D.	33.976–34.000 (1.3376–1.3386)		—
Crankshaft journal oil clearance	0.020–0.044 (0.0008–0.0017)		0.080 (0.0031)
Crankshaft journal O.D.	33.976–34.000 (1.3376–1.3386)		—
Crankshaft thrust clearance	0.055–0.110 (0.0022–0.0043)		—
Crankshaft thrust bearing thickness	Right side	2.425–2.450 (0.0955–0.0965)	—
	Left side	2.350–2.500 (0.0925–0.0984)	—
Crankshaft runout	—		0.05 (0.002)

OIL PUMP

ITEM	STANDARD	LIMIT
Oil pump reduction ratio	1.898 (75/43 x 37/34)	—
Oil pressure (at 60°C, 140°F)	Above 300 kPa (3.0 kg/cm ² , 43 psi) Below 600 kPa (6.0 kg/cm ² , 85 psi) at 3 000 r/min. ~	—

8-35 SERVICING INFORMATION**CLUTCH**

Unit: mm (in)

ITEM	STANDARD	LIMIT
Clutch lever play	10–15 (0.4–0.6)	—
Drive plate thickness	2.12–2.28 (0.083–0.090)	1.82 (0.072)
Driven plate distortion	—	0.10 (0.004)
Clutch spring free length	—	47.5 (1.87)

THERMOSTAT + RADIATOR + FAN

ITEM	STANDARD	LIMIT	
Thermostat valve opening temperature	74.5–78.5°C (166.1–173.3°F)	—	
Thermostat valve lift	Over 7 mm (0.28 in) at 90°C (194°F)	—	
Radiator cap valve opening pressure	110 kPa (1.1 kg/cm ² , 15.6 psi)	—	
Cooling fan thermo-switch operating temperature	ON	Approx. 105°C (221°F)	—
	OFF	Approx. 100°C (212°F)	—
Engine coolant temperature gauge resistance	50°C (122°F)	Approx. 153.9 Ω	—
	80°C (176°F)	Approx. 51.9 Ω	—
	100°C (212°F)	Approx. 27.4 Ω	—
	120°C (248°F)	Approx. 16.1 Ω	—

TRANSMISSION + DRIVE CHAIN

Unit: mm (in) Except ratio

ITEM	STANDARD	LIMIT	
Primary reduction ratio	1.744 (75/43)	—	
Final reduction ratio	3.071 (43/14)	—	
Gear ratios	Low	3.142 (44/14)	—
	2nd	2.058 (35/17)	—
	3rd	1.650 (33/20)	—
	4th	1.428 (30/21)	—
	5th	1.260 (29/23)	—
	Top	1.120 (28/25)	—
Shift fork to groove clearance	0.10–0.30 (0.004–0.012)	0.50 (0.020)	
Shift fork groove width	5.00–5.10 (0.197–0.201)	—	
Shift fork thickness	4.80–4.90 (0.189–0.193)	—	

SERVICING INFORMATION 8-36

ITEM	STANDARD		LIMIT
	Drive chain	Type	
Links		108 links, ENDLESS	—
20-pitch length		—	319.4 (12.6)
Drive chain slack	30—40 (1.2—1.6)		—
Gearshift lever height	55 (2.2)		—

CARBURETOR

ITEM	SPECIFICATION	
	E-03, U.S.A.	E-33, U.S.A. (Calif. model)
Carburetor type	MIKUNI BDST36SS	MIKUNI BDST33SS
Bore size	36 mm	33 mm
I.D. No.	21E4	21E5
Idle r/min.	1 300 ± 100 r/min	1 350 ± 100 r/min
Float height	6.9 ± 1.0 mm (0.27 ± 0.04 in)	←
Main jet (M.J.)	#112.5	#107.5
Main air jet (M.A.J.)	0.6 mm	←
Jet needle (J.N.)	5E97	5E95
Needle jet (N.J.)	□-9	□-8
Throttle valve (Th.V.)	#120	←
Pilot jet (P.J.)	#15	#10
Starter jet (G.S.)	#47.5	←
Pilot screw (P.S.)	PRE-SET	←
Throttle cable play	0.5—1.0 mm (0.02—0.04 in)	

ELECTRICAL

Unit: mm (in)

ITEM	SPECIFICATION		NOTE
Ignition timing	7° B.T.D.C. below 1 500 r/min.		E-03
	4° B.T.D.C. below 1 500 r/min.		E-33
Firing order	1-2-4-3		
Spark plug	Type	NGK: CR9E ND: U27ESR-N	
	Gap	0.7—0.8 (0.028—0.032)	
Spark performance	Over 8 (0.3) at 1 atm.		
Signal coil resistance	(Black—Green) Approx. 135—200 Ω		Tester range: (x 100 Ω)
Ignition coil resistance	Primary	⊕ tap—⊖ tap Approx. 2.4—3.2 Ω	Tester range: (x 1 Ω)
	Secondary	Plug cap—Plug cap Approx. 30—40 kΩ	Tester range: (x 1 kΩ)

8-37 SERVICING INFORMATION

ITEM		SPECIFICATION		NOTE
Generator		Slip ring O.D.	Limit: 14.0 (0.55)	ND
		Brush length	Limit: 4.5 (0.18)	
Generator Max. output		Approx. 405 W at 5 000 r/min		The rotation of the generator
Regulated voltage		Above 13.5 V at 5 000 r/min.		
Starter motor		Commutator under-cut	Limit: 0.2 (0.008)	ND
Starter relay resistance		3-5 Ω		
Battery	Type designation	YTX9-BS		
	Capacity	12 V 28.8 kC (8 Ah)/10 HR		
	Standard electrolyte S.G.	1.320 at 20°C (68°F)		
Fuse size	Headlight	HI	15 A	
		LO	15 A	
	Turn signal		15 A	
	Ignition		10 A	
	Taillight		10 A	
	Main		30 A	

WATTAGE

Unit: W

ITEM		SPECIFICATION	
		E-03,33	The others
Headlight	HI	60	←
	LO	55	←
Position light			4
Taillight		5	←
Brake light		21 x 2	←
Turn signal light		21	←
Tachometer light		1.7 x 2	←
Speedometer light		1.7 x 2	←
Turn signal indicator light		3.4	←
High beam indicator light		3.4	←
Neutral indicator light		3.4	←
Oil pressure indicator light		3.4	←
Fuel level indicator light		3.4	←
License light		5	←
Engine coolant temp. meter light		1.7	←

BRAKE + WHEEL

Unit: mm (in)

ITEM	STANDARD		LIMIT
Rear brake pedal height	55 (2.2)		—
Brake disc thickness	Front	4.5 ± 0.2 (0.177 ± 0.008)	4.0 (0.16)
	Rear	5.0 ± 0.2 (0.197 ± 0.008)	4.5 (0.18)
Brake disc runout (Front & Rear)	—		0.30 (0.012)

SERVICING INFORMATION 8-38

ITEM		STANDARD		LIMIT
Master cylinder bore		Front	12.700—12.743 (0.5000—0.5017)	—
		Rear	12.700—12.743 (0.5000—0.5017)	—
Master cylinder piston diam.		Front	12.657—12.684 (0.4983—0.4993)	—
		Rear	12.657—12.684 (0.4983—0.4993)	—
Brake caliper cylinder bore	Leading	Front	25.400—25.450 (1.0000—1.0020)	—
	Trailing		25.400—25.450 (1.0000—1.0020)	—
		Rear	38.180—38.256 (1.5031—1.5061)	—
Brake caliper piston diam.	Leading	Front	25.335—25.368 (0.9974—0.9987)	—
	Trailing		25.335—25.368 (0.9974—0.9987)	—
		Rear	38.098—38.148 (1.5000—1.5019)	—
Wheel rim runout (Front & Rear)		Axial	—	2.0 (0.08)
		Radial	—	2.0 (0.08)
Wheel axle runout		Front	—	0.25 (0.010)
		Rear	—	0.25 (0.010)
Tire size		Front	120/70 ZR17	—
		Rear	160/60 ZR17	—
Tire tread depth		Front	—	1.6 (0.06)
		Rear	—	2.0 (0.08)

SUSPENSION

Unit: mm (in)

ITEM	STANDARD	LIMIT	NOTE
Front fork stroke	120 (4.7)	—	
Front fork spring free length	—	390 (15.4)	
Front fork oil level	92 (3.6)	—	
Rear wheel travel	130 (5.1)	—	
Swingarm pivot shaft runout	—	0.3 (0.01)	

8-39 SERVICING INFORMATION**TIRE PRESSURE**

COLD INFLATION TIRE PRESSURE	SOLO RIDING			DUAL RIDING		
	kPa	kg/cm ²	psi	kPa	kg/cm ²	psi
FRONT	225	2.25	33	250	2.50	36
REAR	250	2.50	36	290	2.90	42

FUEL + OIL + ENGINE COOLANT

ITEM	SPECIFICATION		NOTE
Fuel type	Use only unleaded gasoline of at least 87 pump octane ($\frac{R+M}{2}$ method) or 91 octane or higher rated by the research method. Gasoline containing MTBE (Methyl Tertiary Butyl Ether), less than 10% ethanol, or less than 5% methanol with appropriate cosolvents and corrosion inhibitor is permissible.		
Fuel tank including reserve	17.0 L (4.5/3.7 US/lmp gal)		E-03
	16.0 L (4.2/3.5 US/lmp gal)		E-33
reserve	4.0 L (1.1/0.9 US/lmp gal)		
Engine oil type	SAE 10W/40, API SE or SF		
Engine oil capacity	Change	3 000 ml (3.2/2.6 US/lmp qt)	
	Filter change	3 300 ml (3.5/2.9 US/lmp qt)	
	Overhaul	3 900 ml (4.1/3.4 US/lmp qt)	
Front fork oil type	Frok oil # 10		
Front fork oil capacity (each leg)	503 ml (17.0/17.7 US/lmp oz)		
Brake fluid type	DOT 4		
Engine coolant type	Use an anti-freeze/coolant compatible with aluminum radiator, mixed with distilled water only, at the ratio of 50:50.		
Engine coolant including reserve	2 450 ml (2.6/2.2 US/lmp qt)		

E-03: U.S.A., E-33: California (U.S.A.)